

Virtual Memory: Systems

15-213/18-213/14-513/15-513: Introduction to Computer Systems
18th Lecture, March 26, 2019

Review of Symbols

Basic Parameters

- $N = 2^n$: Number of addresses in virtual address space
- $M = 2^m$: Number of addresses in physical address space
- $P = 2^p$: Page size (bytes)

Components of the *virtual address* (VA)

- TLBI: TLB index
- TLBT: TLB tag
- VPO: Virtual page offset
- VPN: Virtual page number

Components of the *physical address* (PA)

- PPO: Physical page offset (same as VPO)
- PPN: Physical page number
- CO: Byte offset within cache line
- CI: Cache index
- CT: Cache tag

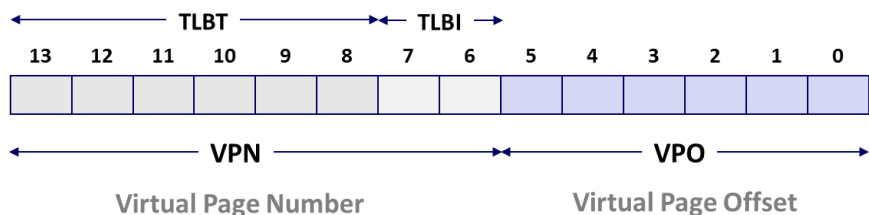
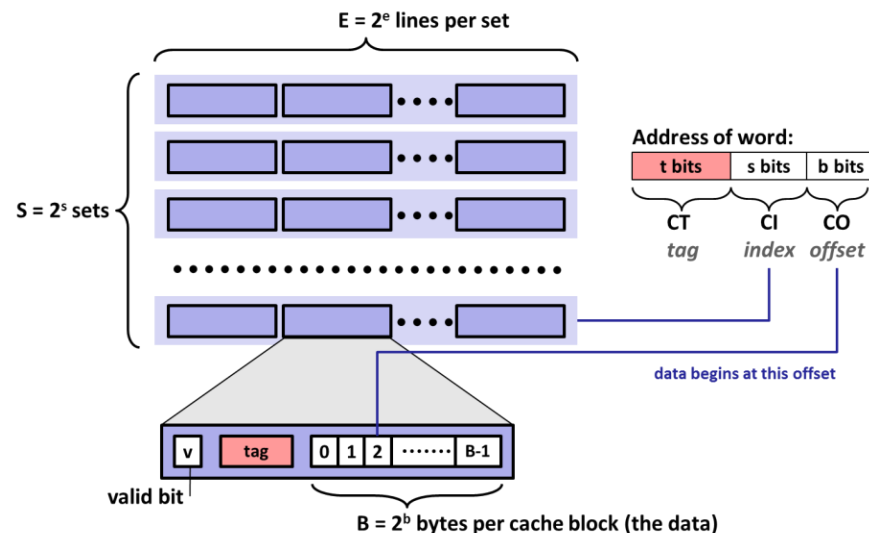

(bits per field for our simple example)

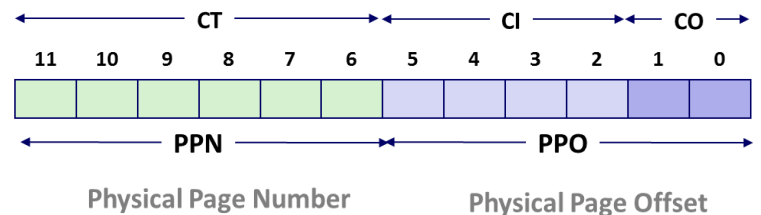

Today

- **Simple memory system example**
- Case study: Core i7/Linux memory system
- Memory mapping

Simple Memory System Example

■ Addressing

- 14-bit virtual addresses
- 12-bit physical address
- Page size = 64 bytes

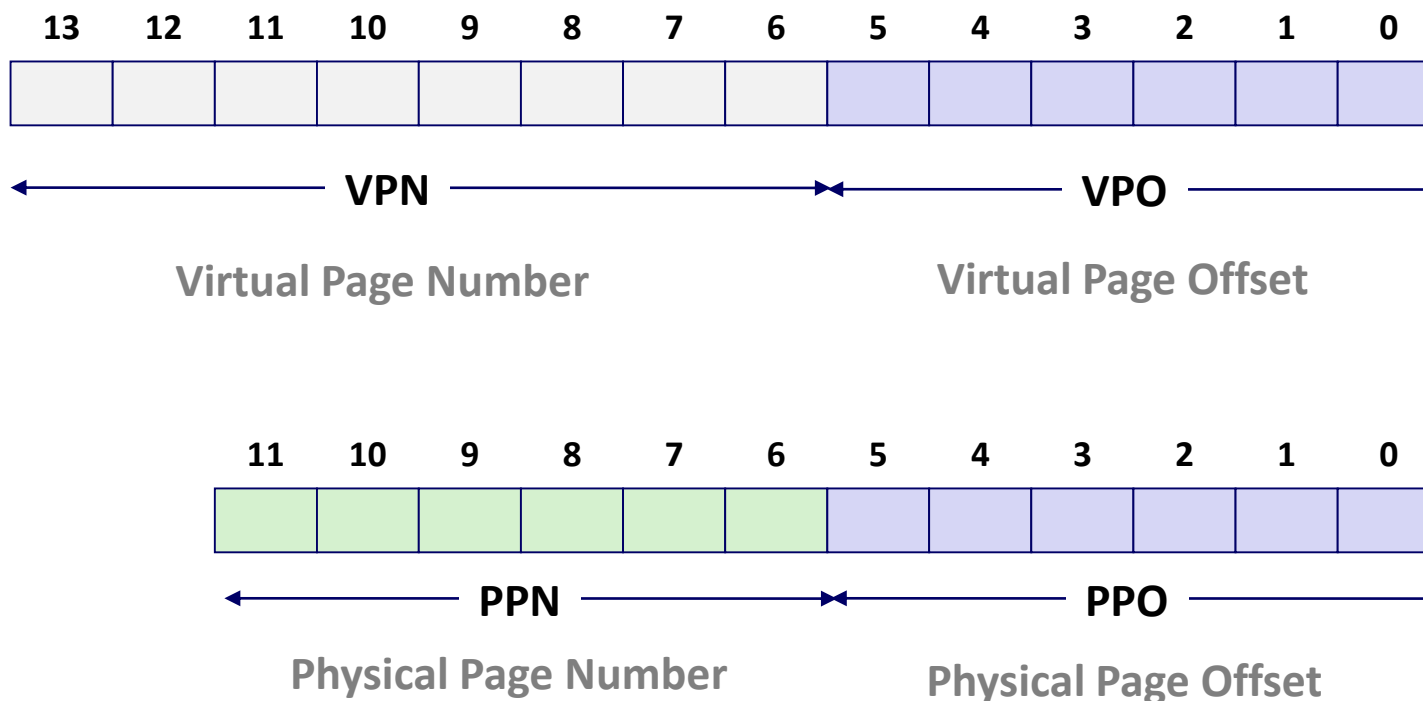

Simple Memory System TLB

- 16 entries
- 4-way associative

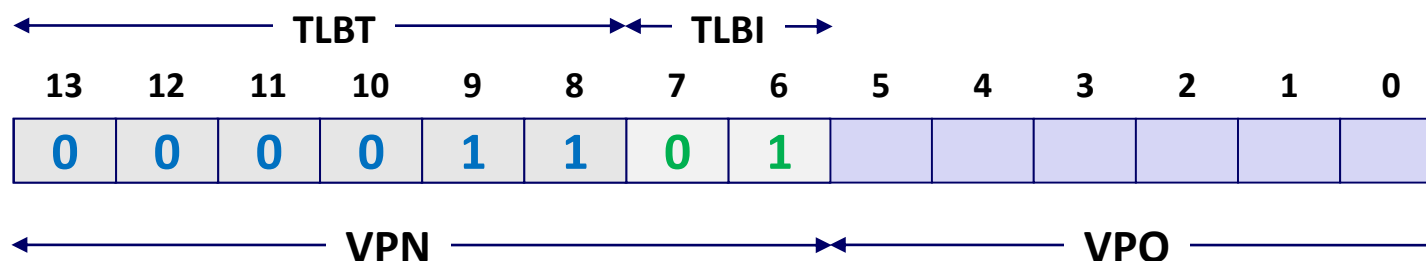

$$\text{VPN} = 0b1101 = 0x0D$$

Translation Lookaside Buffer (TLB)

Set	Tag	PPN	Valid	Tag	PPN	Valid	Tag	PPN	Valid	Tag	PPN	Valid
0	03	-	0	09	0D	1	00	-	0	07	02	1
1	03	2D	1	02	-	0	04	-	0	0A	-	0
2	02	-	0	08	-	0	06	-	0	03	-	0
3	07	-	0	03	0D	1	0A	34	1	02	-	0

Simple Memory System Page Table

Only showing the first 16 entries (out of 256)

<i>VPN</i>	<i>PPN</i>	<i>Valid</i>
00	28	1
01	–	0
02	33	1
03	02	1
04	–	0
05	16	1
06	–	0
07	–	0

<i>VPN</i>	<i>PPN</i>	<i>Valid</i>
08	13	1
09	17	1
0A	09	1
0B	–	0
0C	–	0
0D	2D	1
0E	11	1
0F	0D	1

0x0D → 0x2D

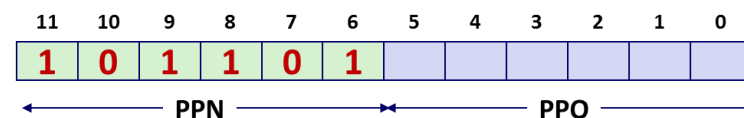
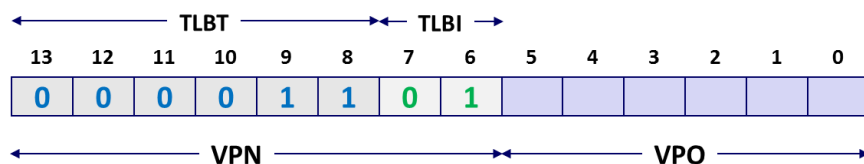

Simple Memory System Cache

- 16 lines, 4-byte cache line size
- Physically addressed
- Direct mapped

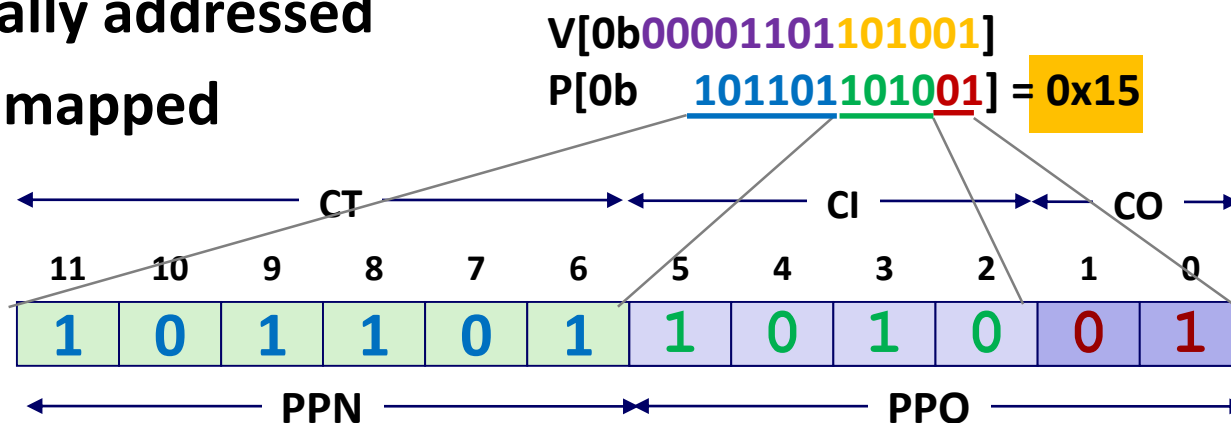

<i>Idx</i>	<i>Tag</i>	<i>Valid</i>	<i>B0</i>	<i>B1</i>	<i>B2</i>	<i>B3</i>
0	19	1	99	11	23	11
1	15	0	–	–	–	–
2	1B	1	00	02	04	08
3	36	0	–	–	–	–
4	32	1	43	6D	8F	09
5	0D	1	36	72	F0	1D
6	31	0	–	–	–	–
7	16	1	11	C2	DF	03

<i>Idx</i>	<i>Tag</i>	<i>Valid</i>	<i>B0</i>	<i>B1</i>	<i>B2</i>	<i>B3</i>
8	24	1	3A	00	51	89
9	2D	0	–	–	–	–
A	2D	1	93	15	DA	3B
B	0B	0	–	–	–	–
C	12	0	–	–	–	–
D	16	1	04	96	34	15
E	13	1	83	77	1B	D3
F	14	0	–	–	–	–

Address Translation Example

Virtual Address: 0x03D4

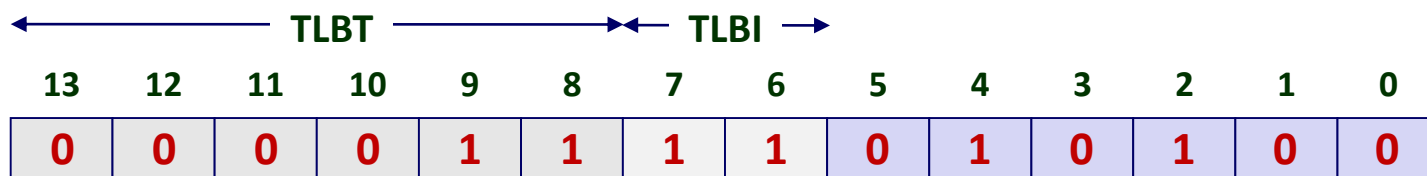

VPN 0x0F TLBI 0x3 TLBT 0x03 TLB Hit? Y Page Fault? N PPN: 0x0D

TLB

Set	Tag	PPN	Valid	Tag	PPN	Valid	Tag	PPN	Valid	Tag	PPN	Valid
0	03	–	0	09	0D	1	00	–	0	07	02	1
1	03	2D	1	02	–	0	04	–	0	0A	–	0
2	02	–	0	08	–	0	06	–	0	03	–	0
3	07	–	0	03	0D	1	0A	34	1	02	–	0

Physical Address

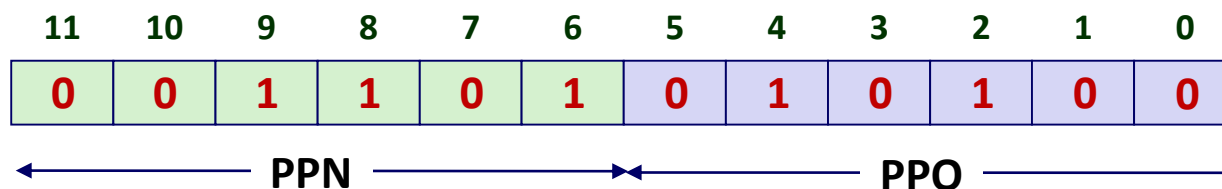

Address Translation Example

Physical Address

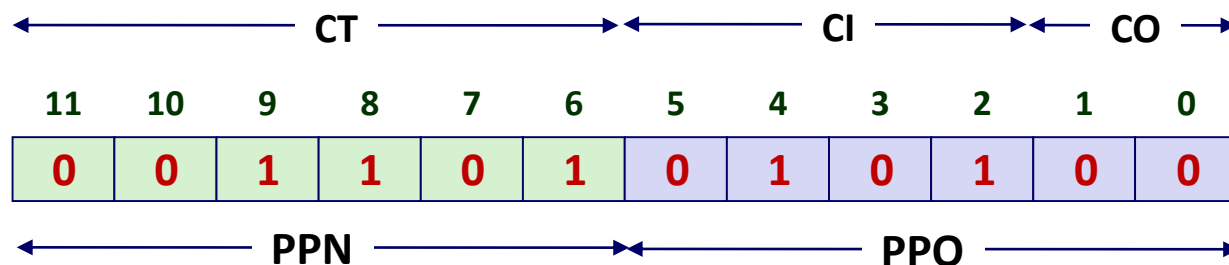

CO 0 CI 0x5 CT 0x0D Hit? Y Byte: 0x36

Cache

Idx	Tag	Valid	B0	B1	B2	B3
0	19	1	99	11	23	11
1	15	0	-	-	-	-
2	1B	1	00	02	04	08
3	36	0	-	-	-	-
4	32	1	43	6D	8F	09
5	0D	1	36	72	F0	1D
6	31	0	-	-	-	-
7	16	1	11	C2	DF	03

Idx	Tag	Valid	B0	B1	B2	B3
8	24	1	3A	00	51	89
9	2D	0	-	-	-	-
A	2D	1	93	15	DA	3B
B	0B	0	-	-	-	-
C	12	0	-	-	-	-
D	16	1	04	96	34	15
E	13	1	83	77	1B	D3
F	14	0	-	-	-	-

Address Translation Example: TLB/Cache Miss

Virtual Address: 0x0020

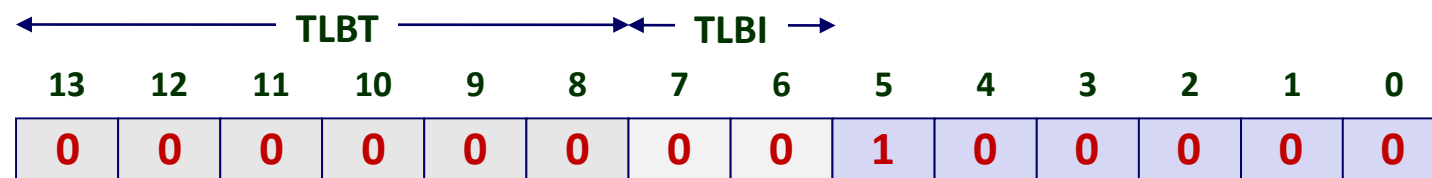

VPN 0x00 TLBI 0 TLBT 0x00 TLB Hit? N Page Fault? N PPN: 0x28

Physical Address

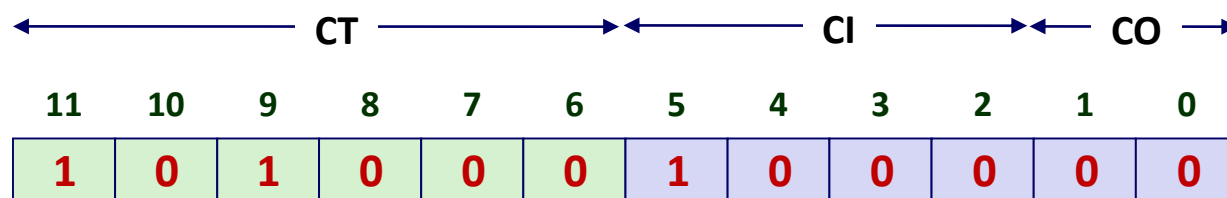

CO 0 CI 0x8 CT 0x28 Hit? __ Byte: _____

Page table

VPN	PPN	Valid
00	28	1
01	-	0
02	33	1
03	02	1
04	-	0
05	16	1
06	-	0
07	-	0

Address Translation Example: TLB/Cache Miss

Cache

Idx	Tag	Valid	B0	B1	B2	B3
0	19	1	99	11	23	11
1	15	0	–	–	–	–
2	1B	1	00	02	04	08
3	36	0	–	–	–	–
4	32	1	43	6D	8F	09
5	0D	1	36	72	F0	1D
6	31	0	–	–	–	–
7	16	1	11	C2	DF	03

Idx	Tag	Valid	B0	B1	B2	B3
8	24	1	3A	00	51	89
9	2D	0	–	–	–	–
A	2D	1	93	15	DA	3B
B	0B	0	–	–	–	–
C	12	0	–	–	–	–
D	16	1	04	96	34	15
E	13	1	83	77	1B	D3
F	14	0	–	–	–	–

Physical Address

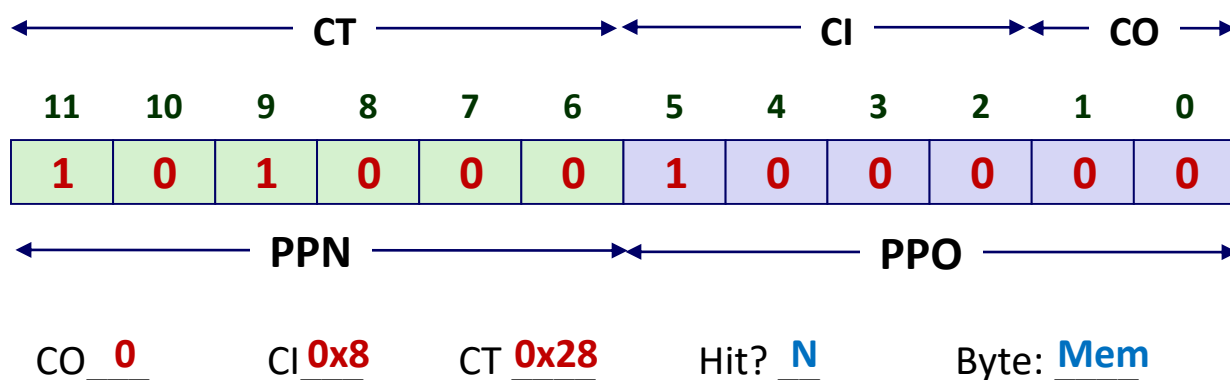

Today

- Simple memory system example
- **Case study: Core i7/Linux memory system**
- Memory mapping

Intel Core i7 Memory System

Processor package

Core x4

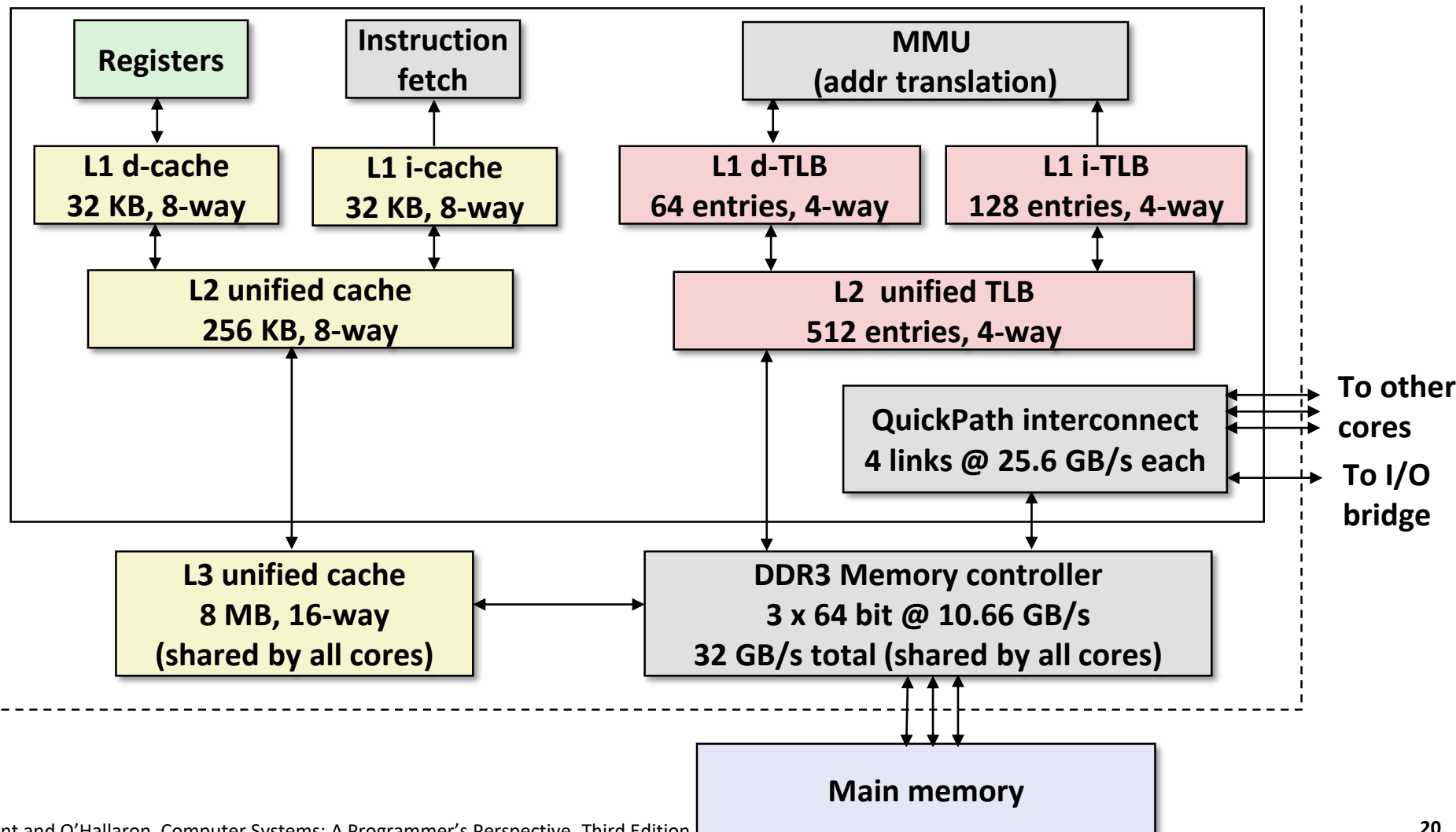

End-to-end Core i7 Address Translation

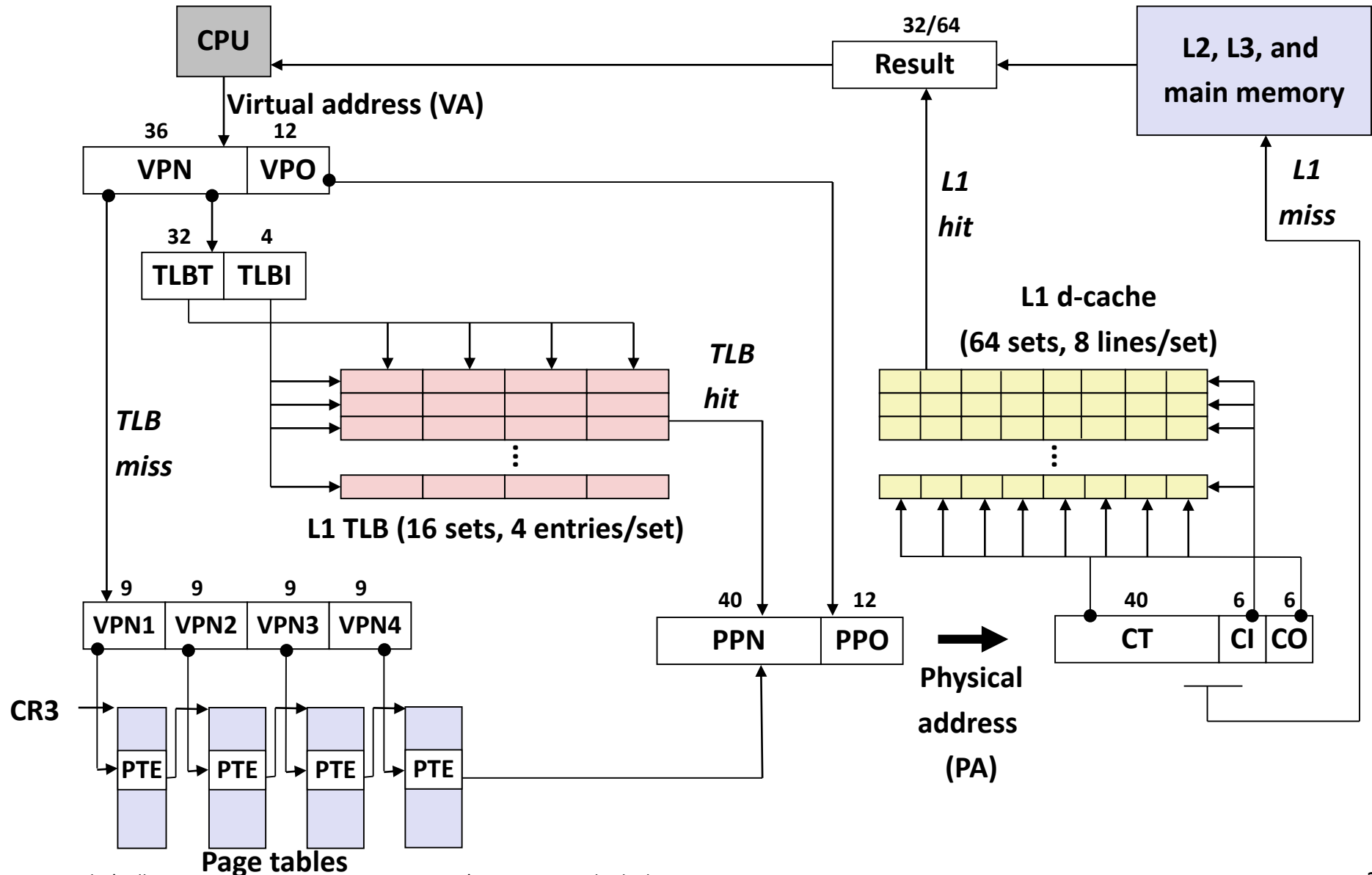

Core i7 Level 1-3 Page Table Entries

63	62	52	51	12	11	9	8	7	6	5	4	3	2	1	0
XD	Unused	Page table physical base address			Unused	G	PS		A	CD	WT	U/S	R/W	P=1	
Available for OS (page table location on disk)														P=0	

Each entry references a 4K child page table. Significant fields:

P: Child page table present in physical memory (1) or not (0).

R/W: Read-only or read-write access access permission for all reachable pages.

U/S: user or supervisor (kernel) mode access permission for all reachable pages.

WT: Write-through or write-back cache policy for the child page table.

A: Reference bit (set by MMU on reads and writes, cleared by software).

PS: Page size either 4 KB or 4 MB (defined for Level 1 PTEs only).

Page table physical base address: 40 most significant bits of physical page table address (forces page tables to be 4KB aligned)

XD: Disable or enable instruction fetches from all pages reachable from this PTE.

G: Process global – pages readable by all processes, subject to access restrictions

Core i7 Level 4 Page Table Entries

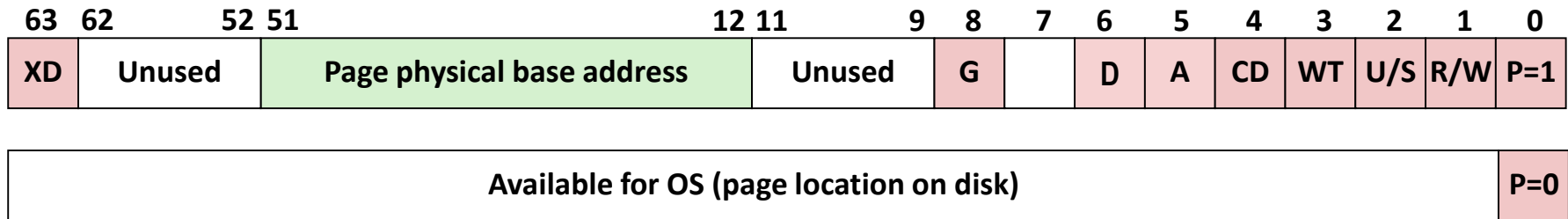

Each entry references a 4K child page. Significant fields:

P: Child page is present in memory (1) or not (0)

R/W: Read-only or read-write access permission for child page

U/S: User or supervisor mode access

WT: Write-through or write-back cache policy for this page

A: Reference bit (set by MMU on reads and writes, cleared by software)

D: Dirty bit (set by MMU on writes, cleared by software)

Page physical base address: 40 most significant bits of physical page address
(40 out of 52 bits; 12 remaining bits address the page & force 4KB alignment)

XD: Disable or enable instruction fetches from this page.

Core i7 Page Table Translation

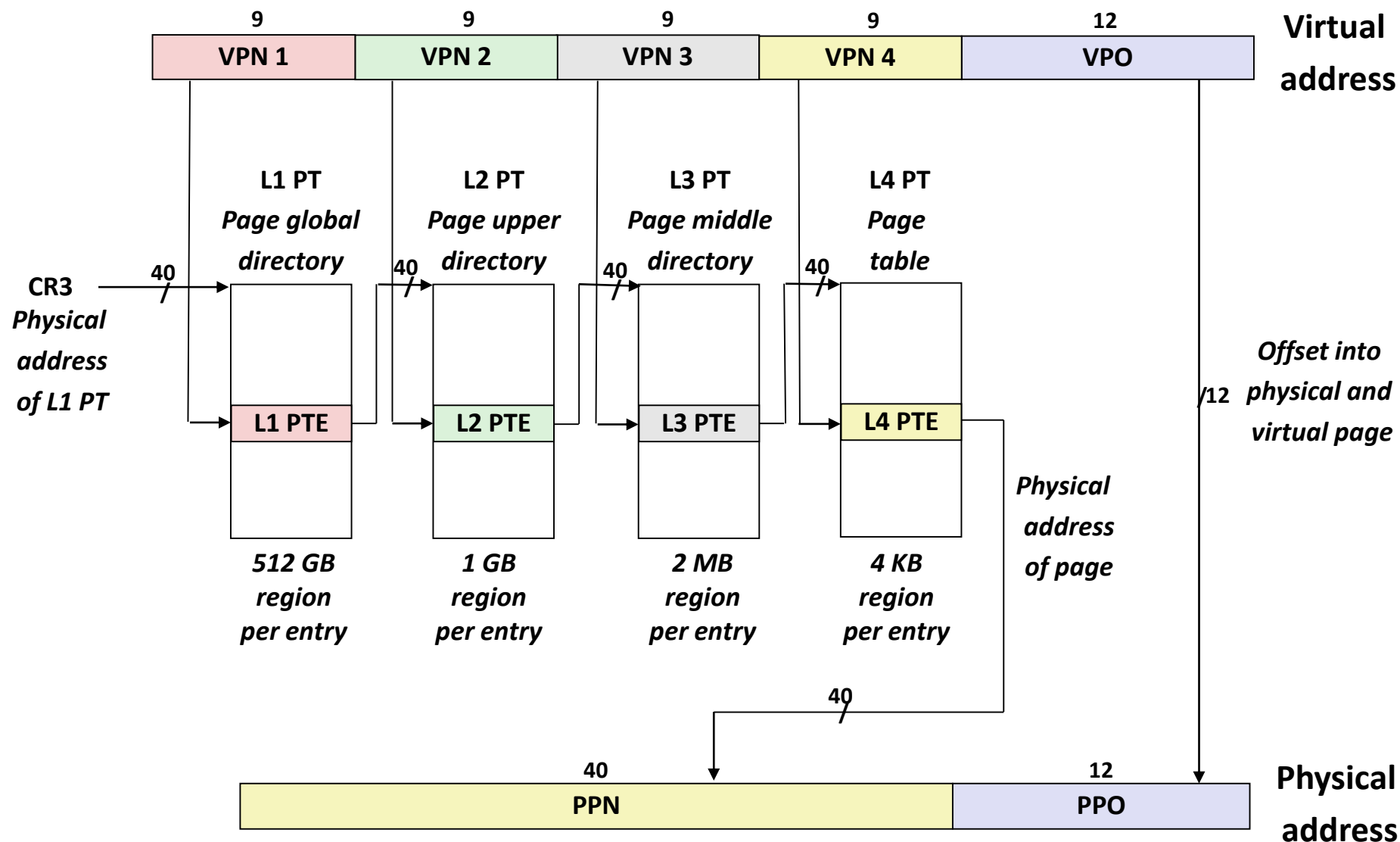

Cute Trick for Speeding Up L1 Access

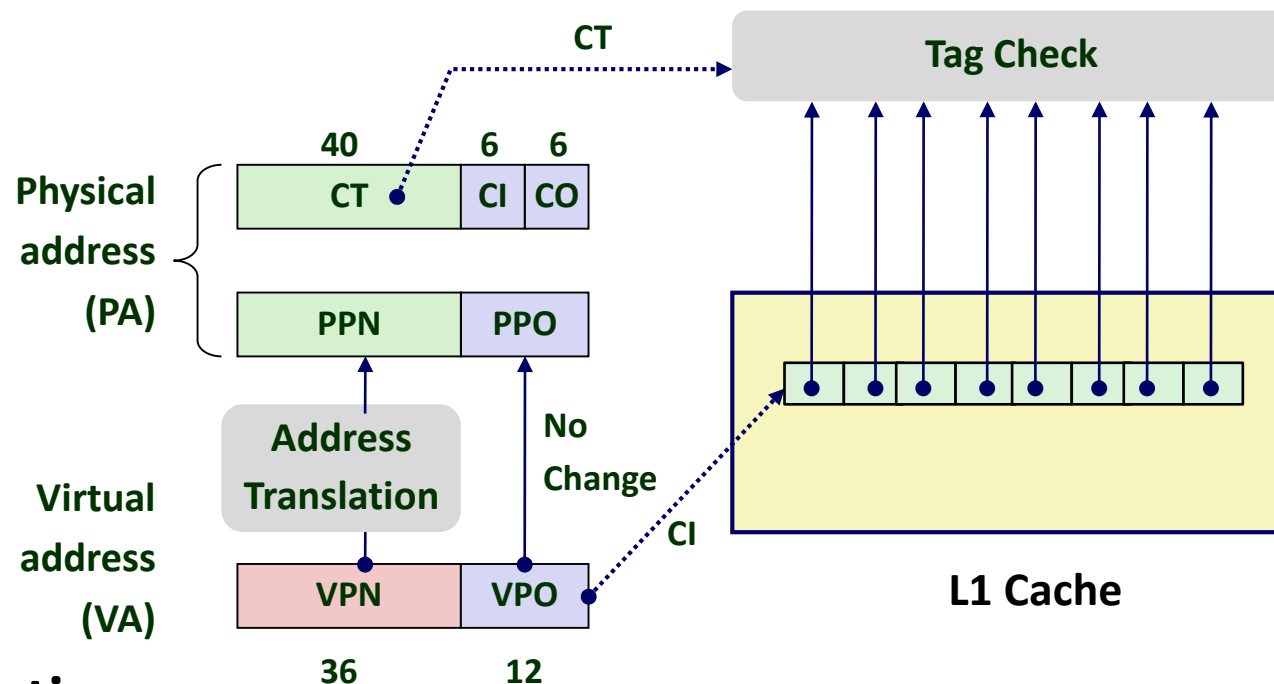

■ Observation

- Bits that determine CI identical in virtual and physical address
- Can index into cache while address translation taking place
- Generally we hit in TLB, so PPN bits (CT bits) available next
- ***“Virtually indexed, physically tagged”***
- Cache carefully sized to make this possible