

Today

- **Storage technologies and trends**
- **Locality of reference**
- **Caching in the memory hierarchy**

Random-Access Memory (RAM)

■ Key features

- **RAM** is traditionally packaged as a chip.
- Basic storage unit is normally a **cell** (one bit per cell).
- Multiple RAM chips form a memory.

■ RAM comes in two varieties:

- SRAM (Static RAM)
- DRAM (Dynamic RAM)

SRAM vs DRAM Summary

	Trans. per bit	Access time	Needs refresh?	Needs EDC?	Cost	Applications
SRAM	4 or 6	1X	No	Maybe	100x	Cache memories
DRAM	1	10X	Yes	Yes	1X	Main memories, frame buffers

Enhanced DRAMs

- **Basic DRAM cell has not changed since its invention in 1966.**
 - Commercialized by Intel in 1970.
- **DRAM cores with better interface logic and faster I/O :**
 - Synchronous DRAM (**SDRAM**)
 - Uses a conventional clock signal instead of asynchronous control
 - Allows reuse of the row addresses (e.g., RAS, CAS, CAS, CAS)
 - Double data-rate synchronous DRAM (**DDR SDRAM**)
 - Double edge clocking sends two bits per cycle per pin
 - Different types distinguished by size of small prefetch buffer:
 - **DDR** (2 bits), **DDR2** (4 bits), **DDR3** (8 bits)
 - By 2010, standard for most server and desktop systems
 - Intel Core i7 supports DDR3 and DDR4 SDRAM

Nonvolatile Memories

- **DRAM and SRAM are volatile memories**
 - Lose information if powered off.
- **Nonvolatile memories retain value even if powered off**
 - Read-only memory (**ROM**): programmed during production
 - Programmable ROM (**PROM**): can be programmed once
 - Erasable PROM (**EPROM**): can be bulk erased (UV, X-Ray)
 - Electrically erasable PROM (**EEPROM**): electronic erase capability
 - Flash memory: EEPROMs. with partial (block-level) erase capability
 - Wears out after about 100,000 erasings
- **Uses for Nonvolatile Memories**
 - Firmware programs stored in a ROM (BIOS, controllers for disks, network cards, graphics accelerators, security subsystems,...)
 - Solid state disks (replace rotating disks in thumb drives, smart phones, mp3 players, tablets, laptops,...)
 - Disk caches

Traditional Bus Structure Connecting CPU and Memory

- A **bus** is a collection of parallel wires that carry address, data, and control signals.
- Buses are typically shared by multiple devices.

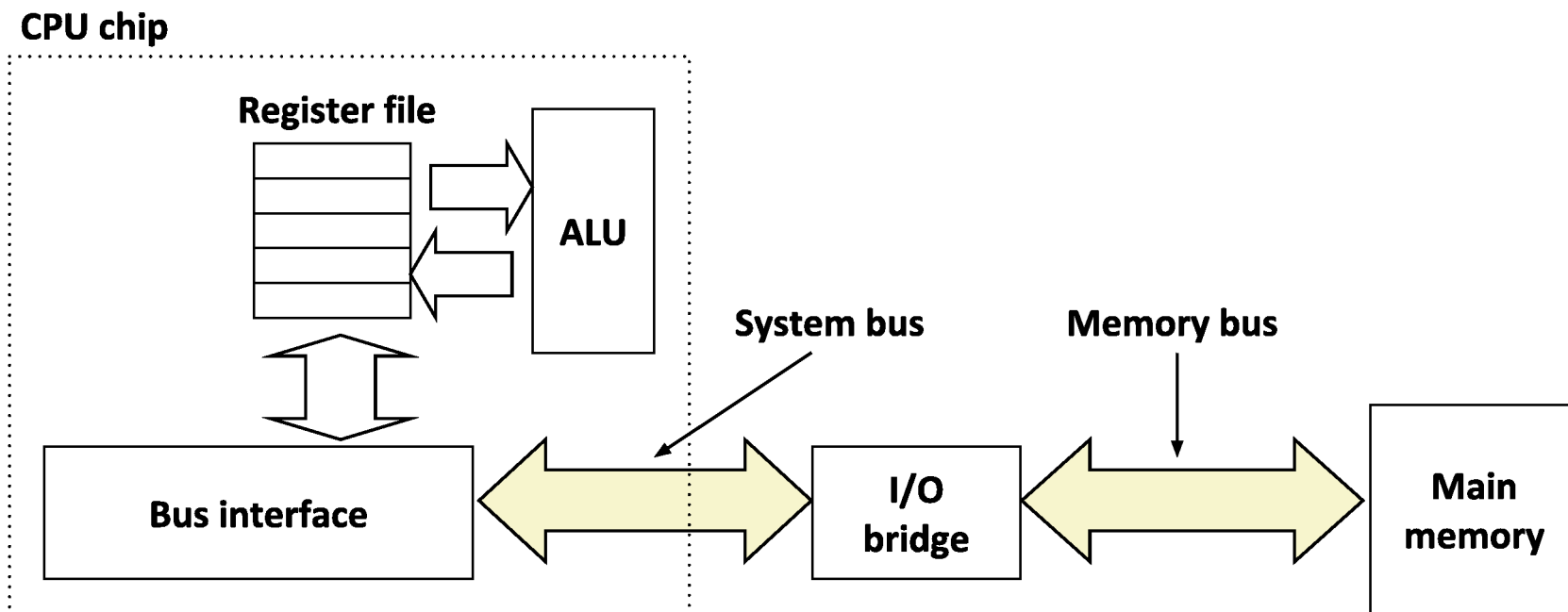

Memory Read Transaction (1)

- CPU places address A on the memory bus.

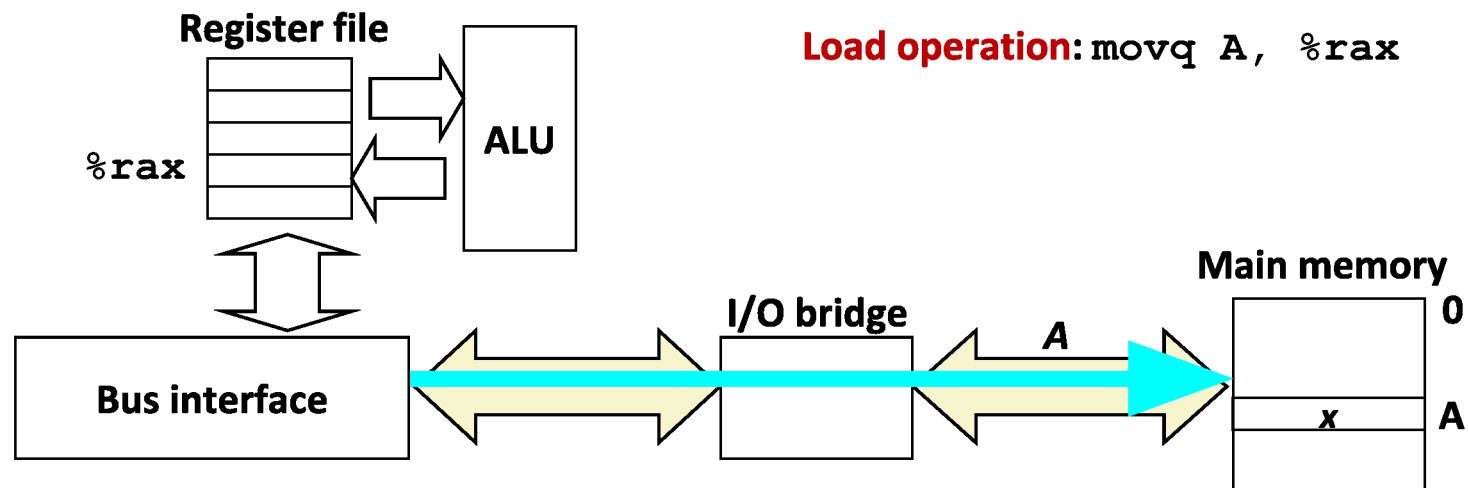

Memory Read Transaction (2)

- Main memory reads A from the memory bus, retrieves word x , and places it on the bus.

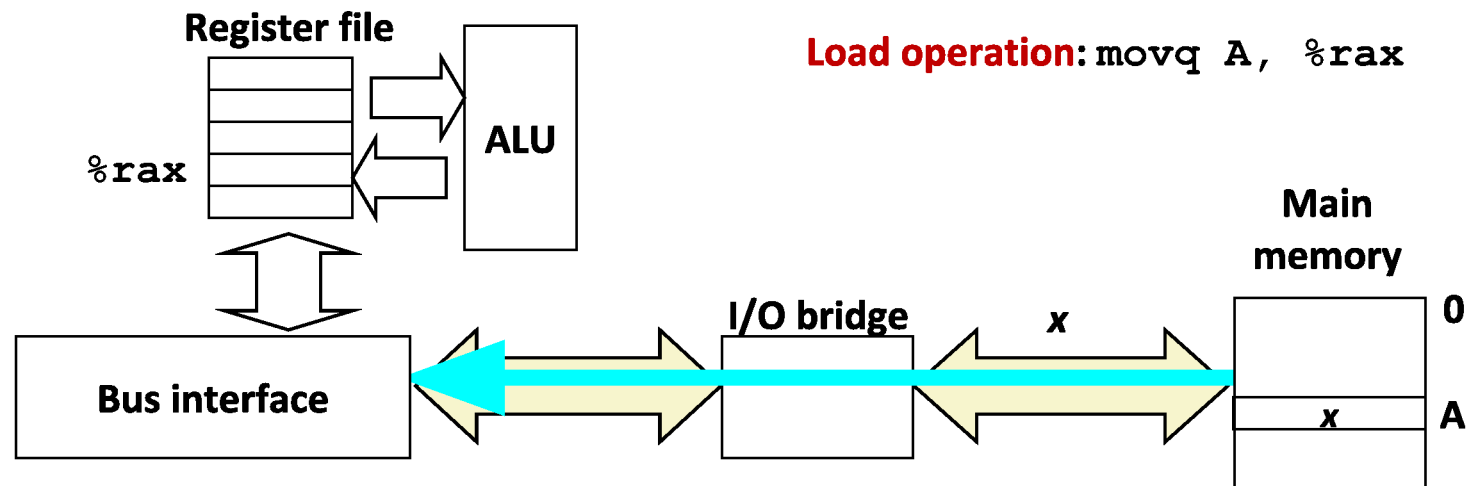

Memory Read Transaction (3)

- CPU read word x from the bus and copies it into register $\%rax$.

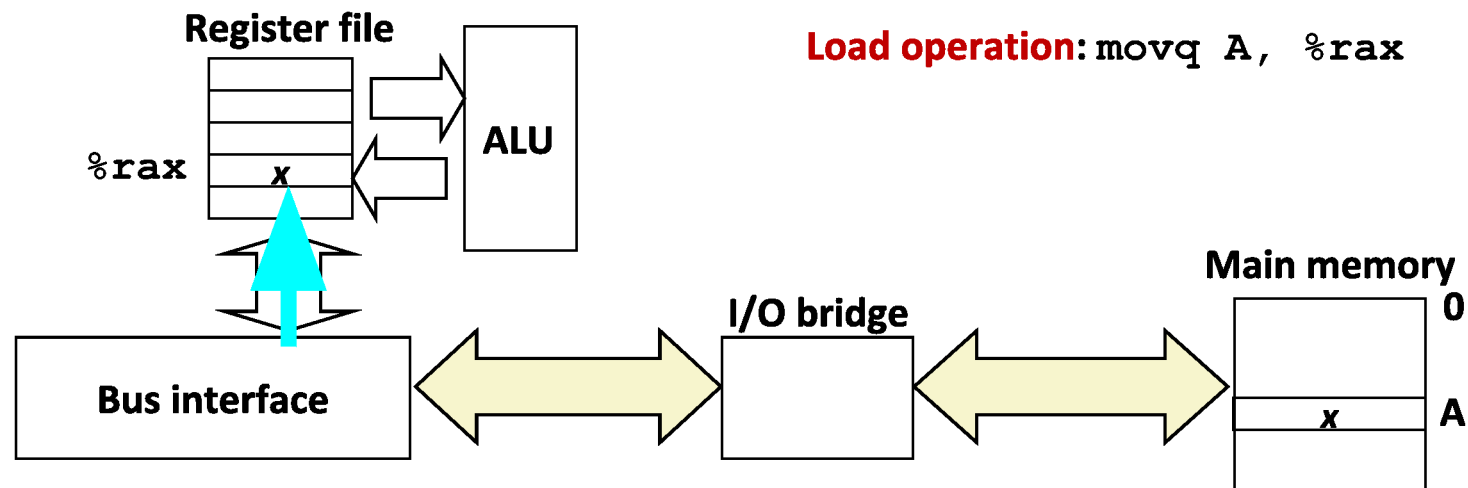

Memory Write Transaction (1)

- CPU places address A on bus. Main memory reads it and waits for the corresponding data word to arrive.

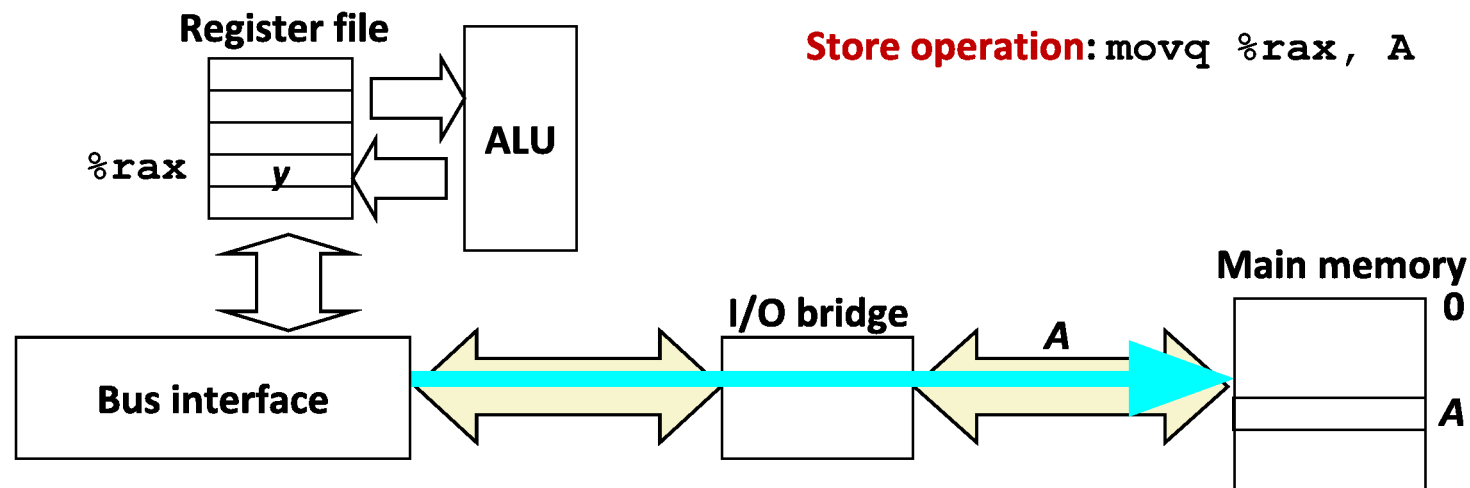

Memory Write Transaction (2)

- CPU places data word y on the bus.

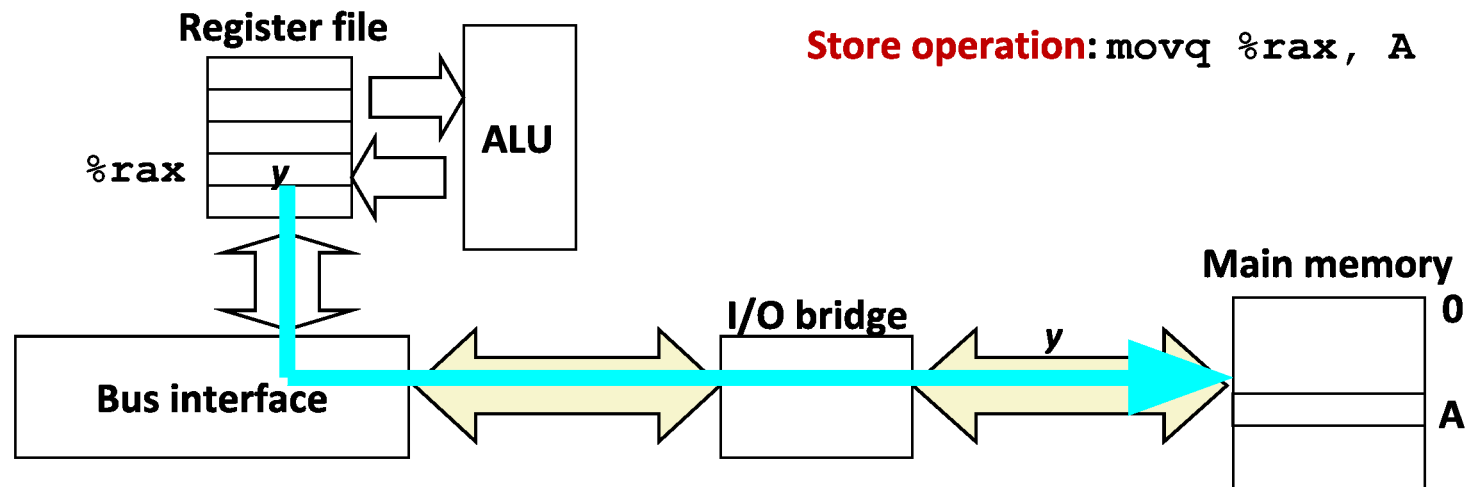

Memory Write Transaction (3)

- Main memory reads data word y from the bus and stores it at address A .

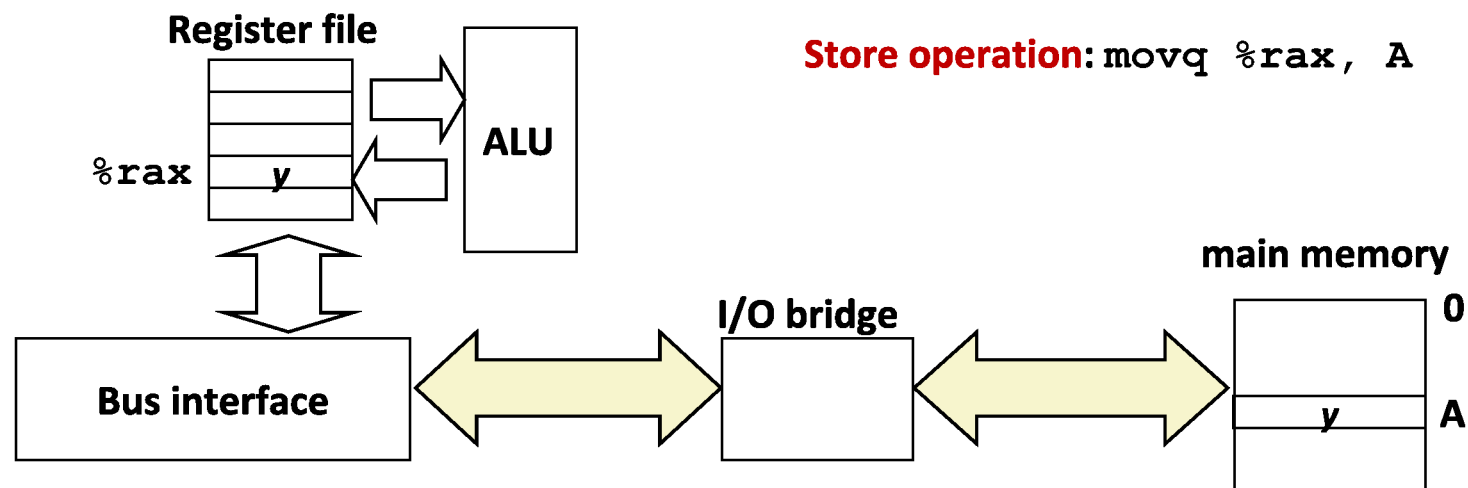

What's Inside A Disk Drive?

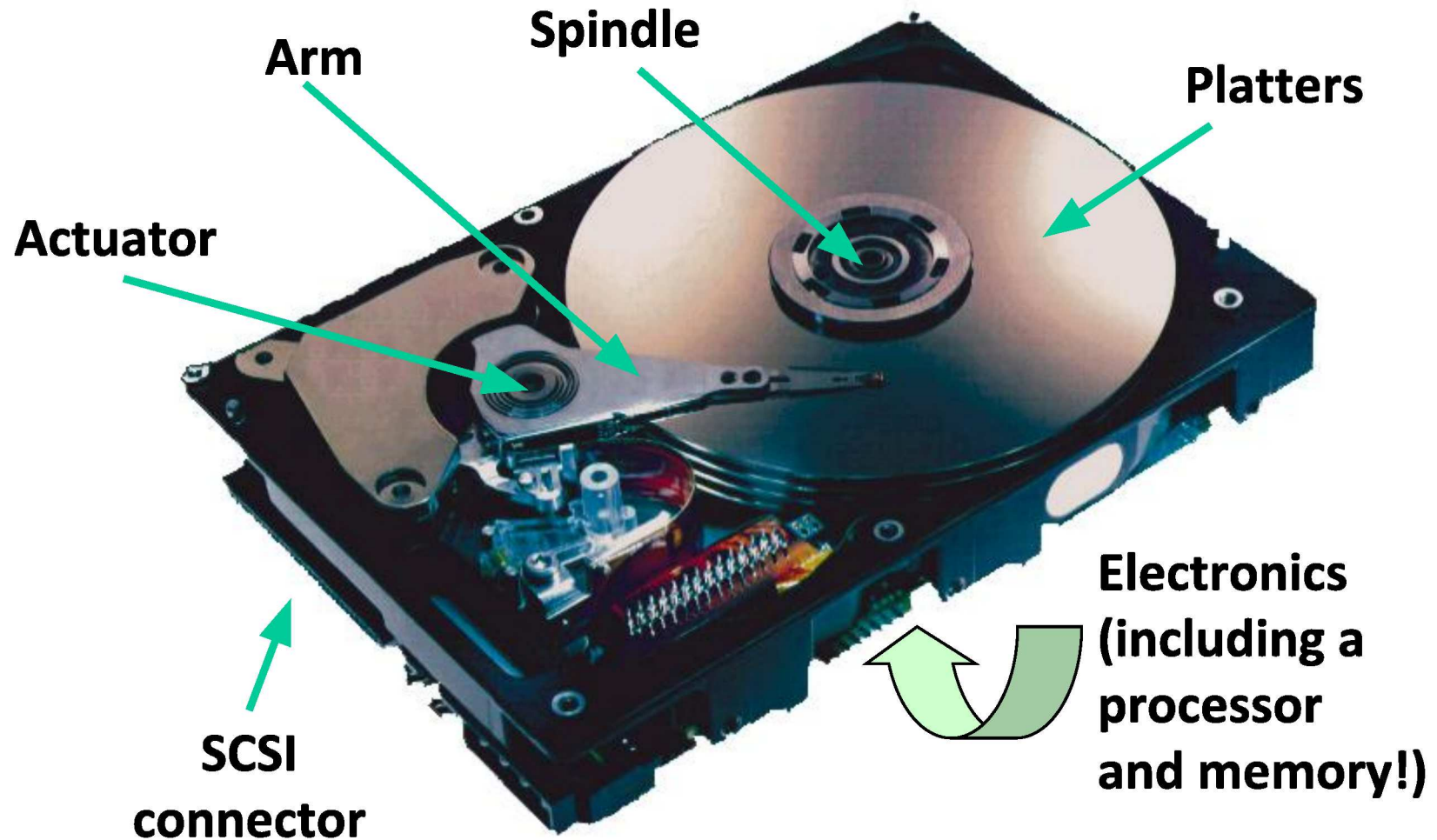
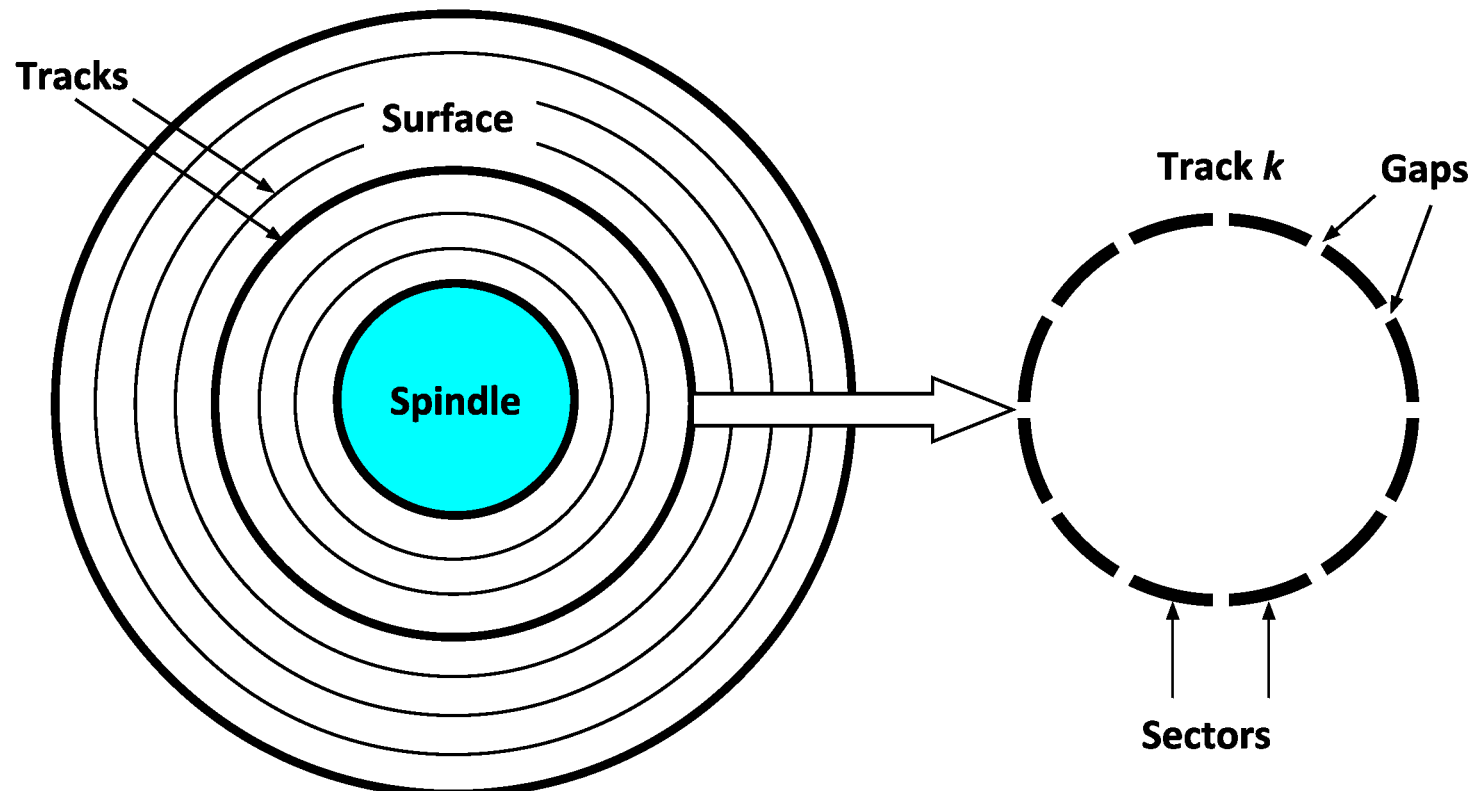

Image courtesy of Seagate Technology

Disk Geometry

- Disks consist of **platters**, each with two **surfaces**.
- Each surface consists of concentric rings called **tracks**.
- Each track consists of **sectors** separated by **gaps**.



Disk Geometry (Multiple-Platter View)

- Aligned tracks form a cylinder.

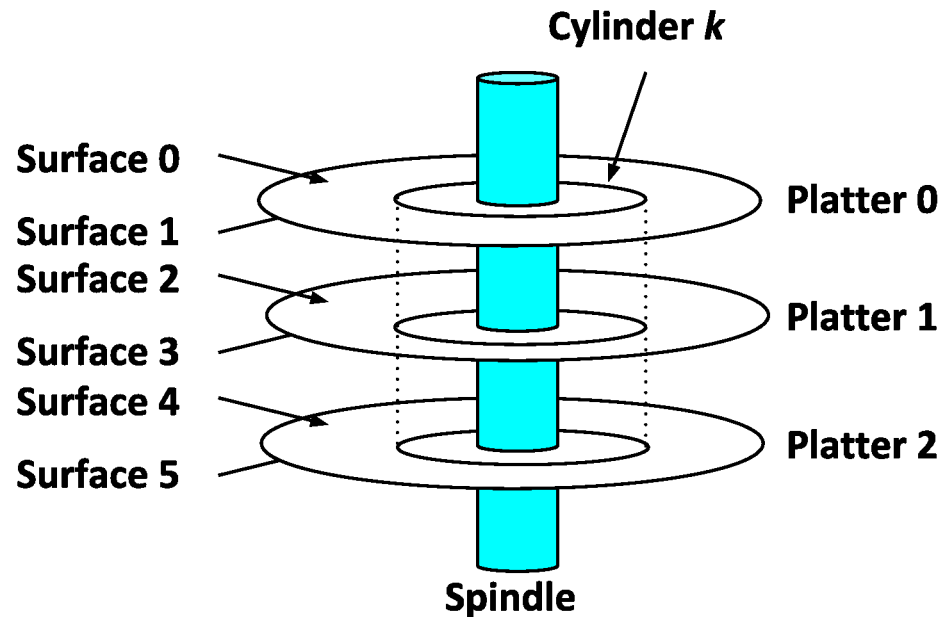

Disk Capacity

- **Capacity:** maximum number of bits that can be stored.
 - Vendors express capacity in units of gigabytes (GB), where $1 \text{ GB} = 10^9 \text{ Bytes}$.
- **Capacity is determined by these technology factors:**
 - **Recording density** (bits/in): number of bits that can be squeezed into a 1 inch segment of a track.
 - **Track density** (tracks/in): number of tracks that can be squeezed into a 1 inch radial segment.
 - **Areal density** (bits/in²): product of recording and track density.

Recording zones

- Modern disks partition tracks into disjoint subsets called **recording zones**
 - Each track in a zone has the same number of sectors, determined by the circumference of innermost track.
 - Each zone has a different number of sectors/track, outer zones have more sectors/track than inner zones.
 - So we use **average** number of sectors/track when computing capacity.

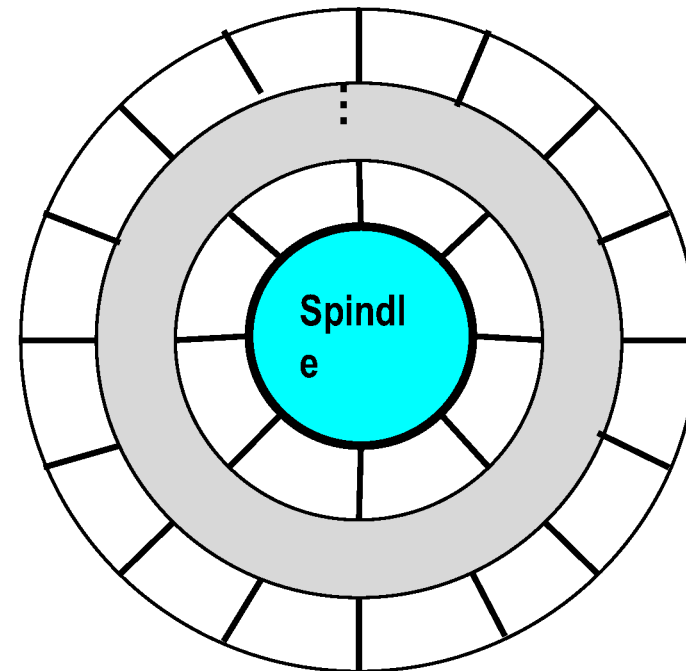

Computing Disk Capacity

**Capacity = (# bytes/sector) x (avg. # sectors/track) x
(# tracks/surface) x (# surfaces/platter) x
(# platters/disk)**

Example:

- 512 bytes/sector
- 300 sectors/track (on average)
- 20,000 tracks/surface
- 2 surfaces/platter
- 5 platters/disk

**Capacity = 512 x 300 x 20,000 x 2 x 5
= 30,720,000,000
= 30.72 GB**

Disk Operation (Single-Platter View)

The disk surface spins at a fixed rotational rate

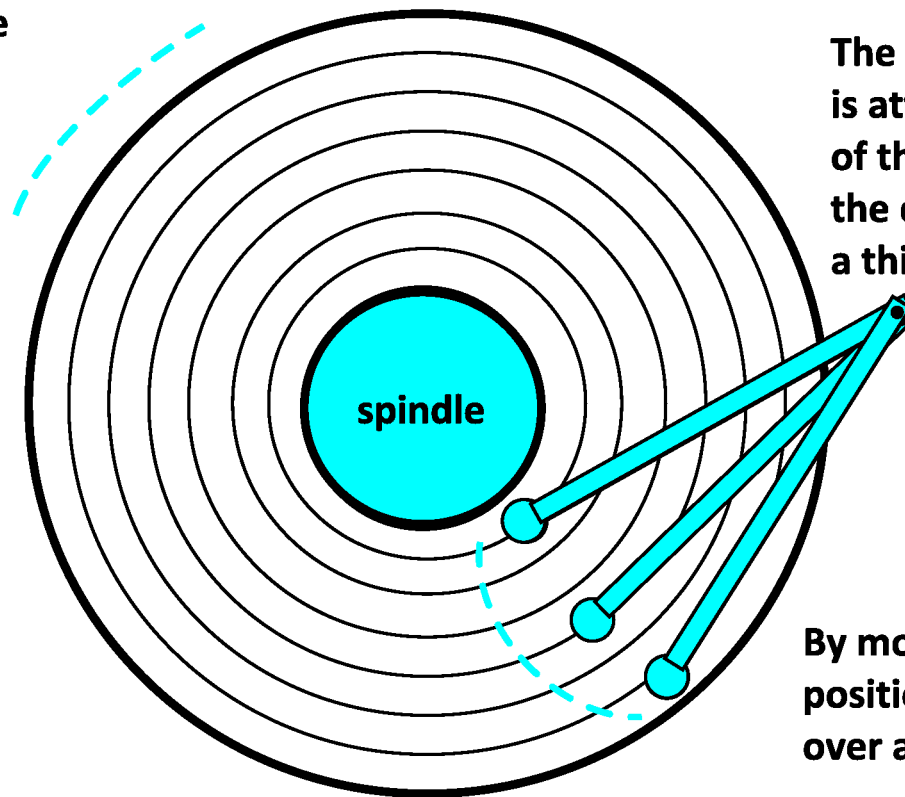

The read/write *head* is attached to the end of the *arm* and flies over the disk surface on a thin cushion of air.

By moving radially, the arm can position the read/write head over any track.

Disk Operation (Multi-Platter View)

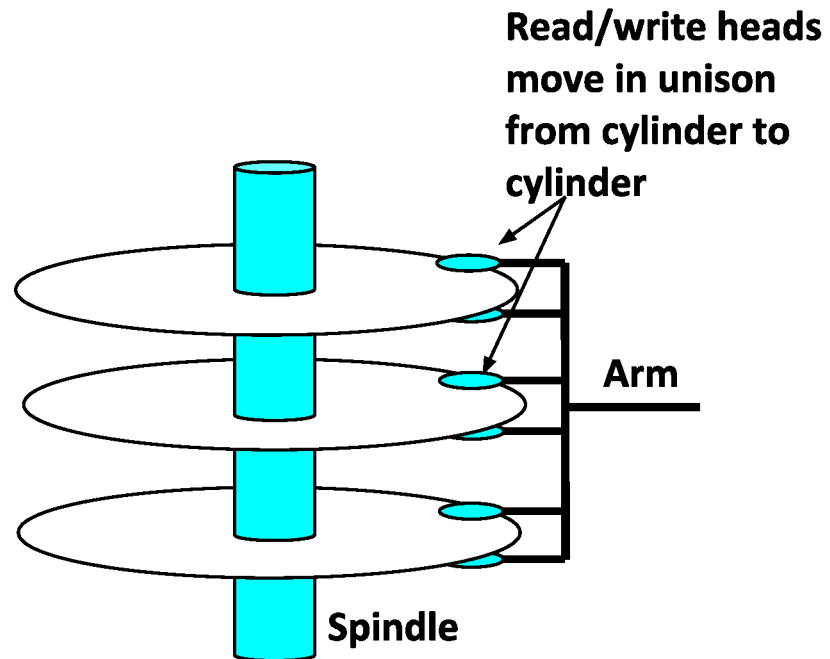

Disk Structure - top view of single platter

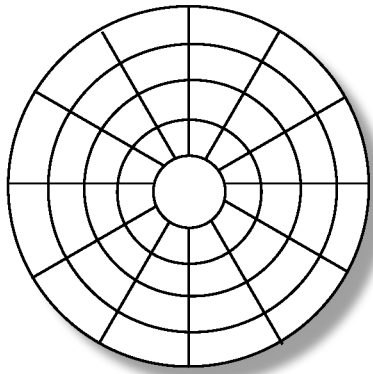

Surface organized into tracks

Tracks divided into sectors

Disk Access

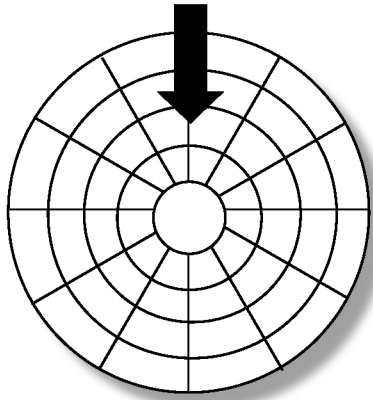

Head in position above a track

Disk Access

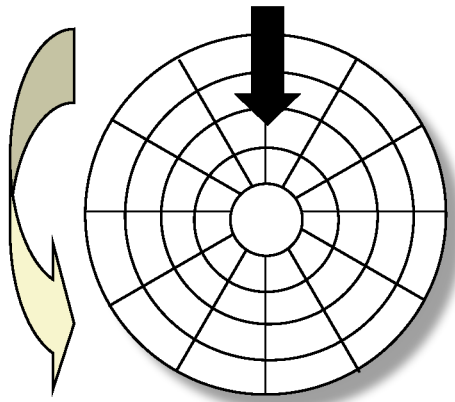

Rotation is counter-clockwise

Disk Access – Read

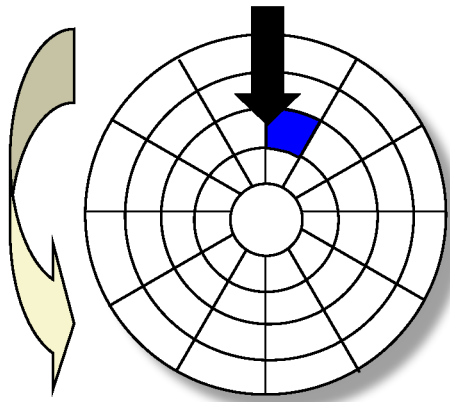

About to read blue sector

Disk Access – Read

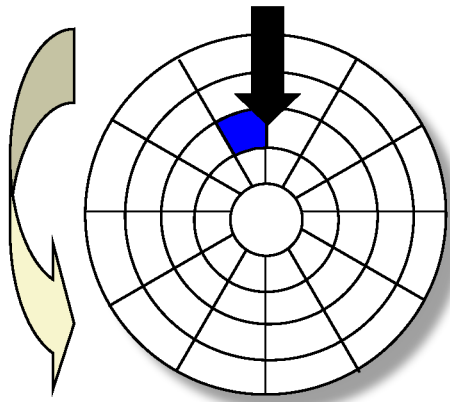

After **BLUE** read

After reading blue sector

Disk Access – Read

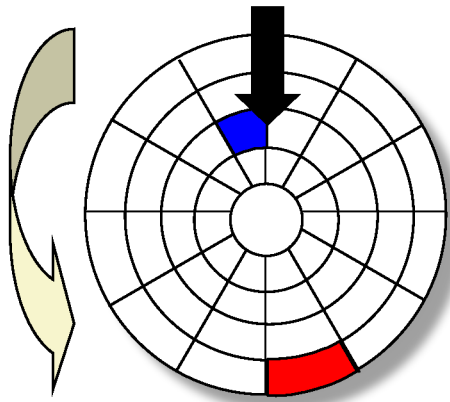

After **BLUE** read

Red request scheduled next

Disk Access – Seek

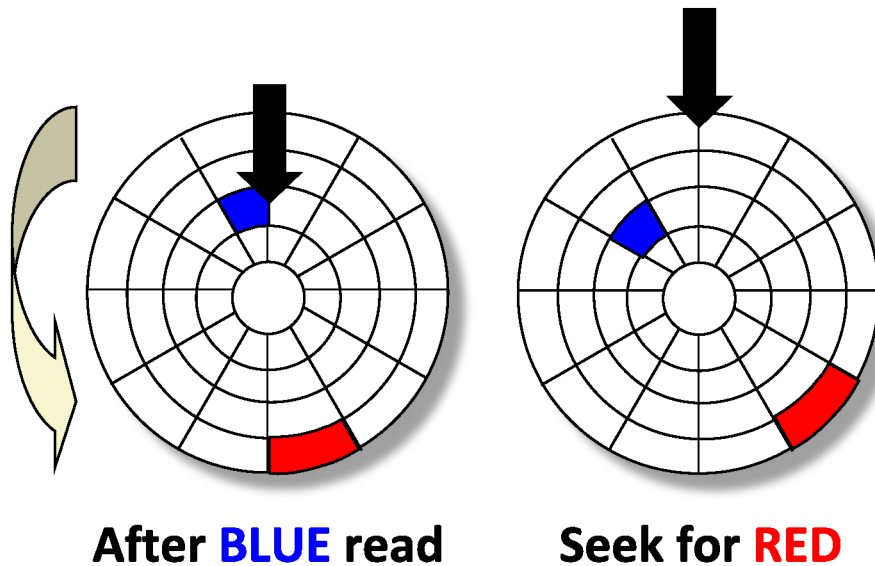

Seek to red's track

Disk Access – Rotational Latency

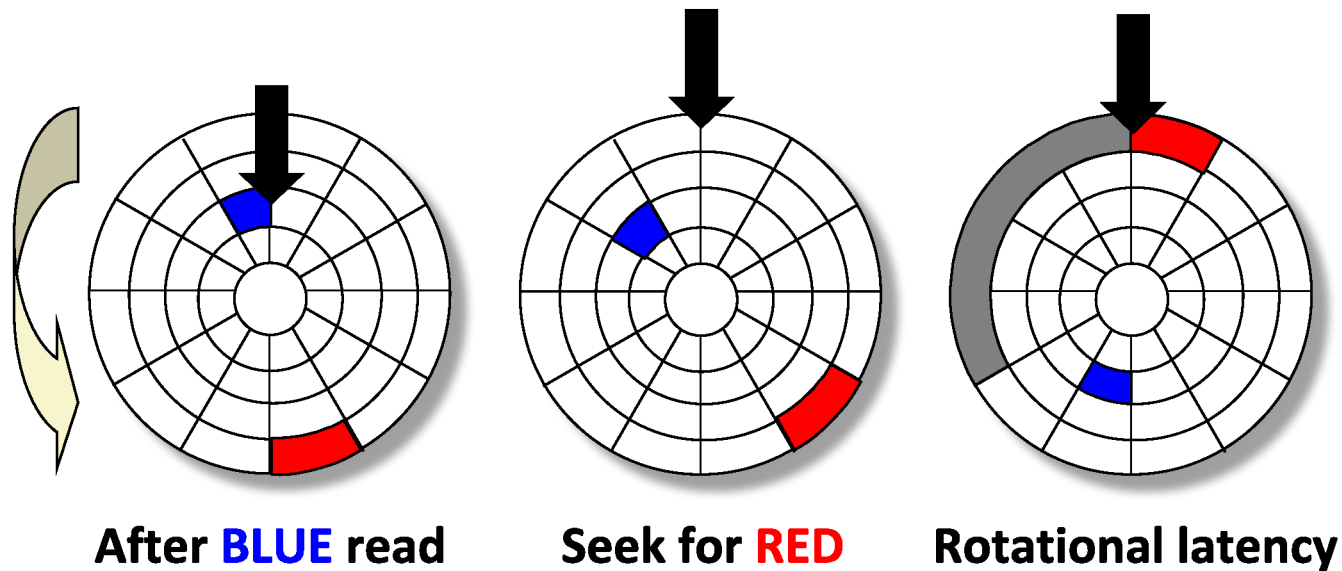

Wait for red sector to rotate around

Disk Access – Read

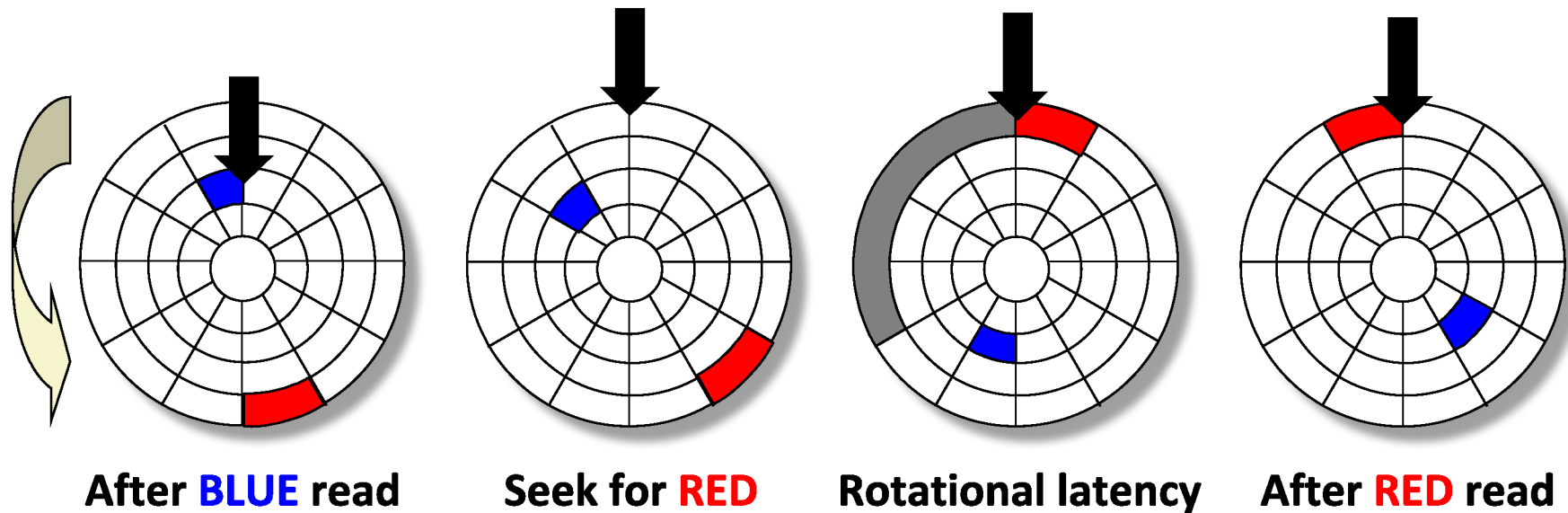

Complete read of red

Disk Access – Service Time Components

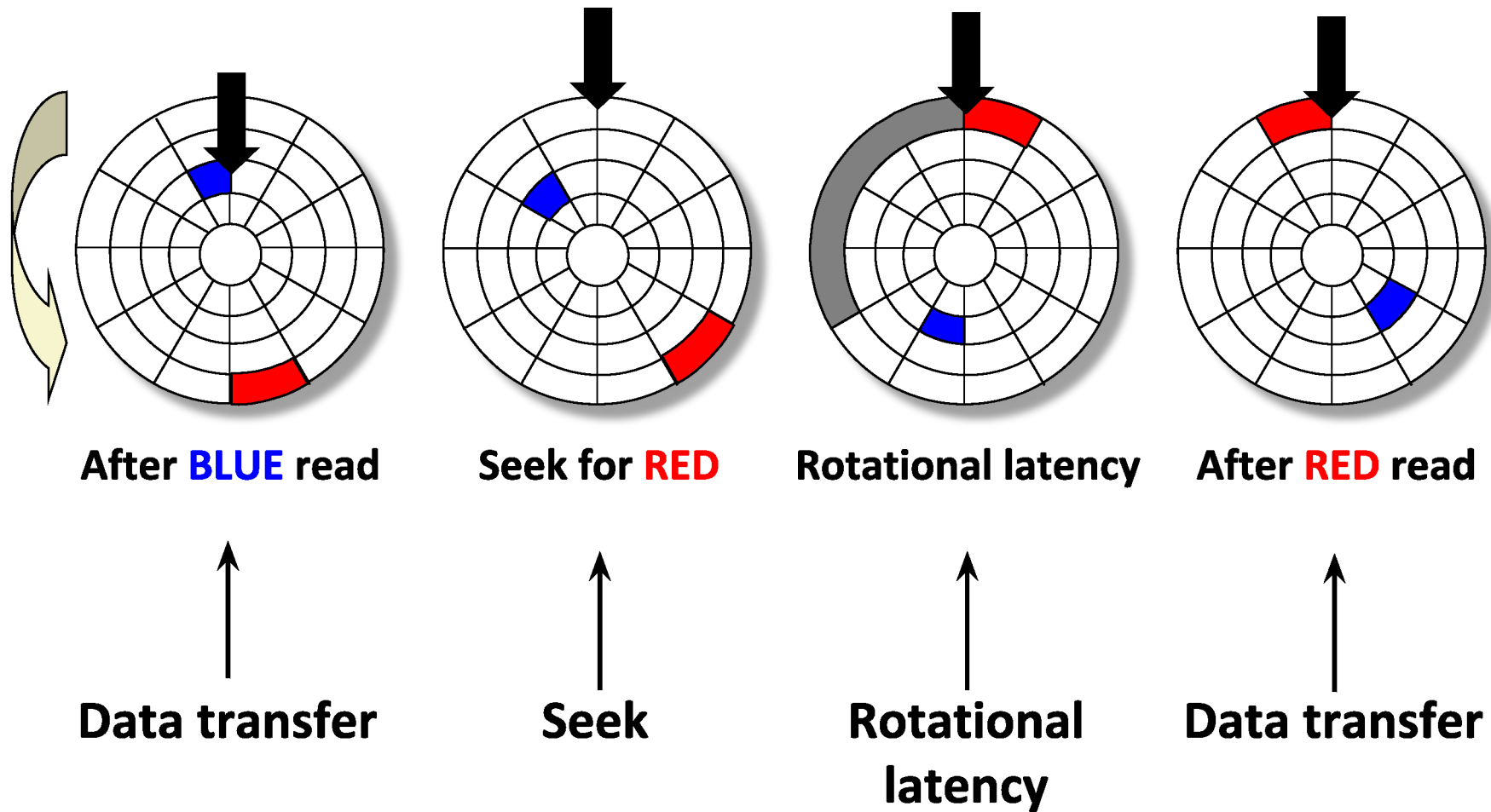

Disk Access Time

- **Average time to access some target sector approximated by:**

- $T_{\text{access}} = T_{\text{avg seek}} + T_{\text{avg rotation}} + T_{\text{avg transfer}}$

- **Seek time ($T_{\text{avg seek}}$)**

- Time to position heads over cylinder containing target sector.
 - Typical $T_{\text{avg seek}}$ is 3—9 ms

- **Rotational latency ($T_{\text{avg rotation}}$)**

- Time waiting for first bit of target sector to pass under r/w head.
 - $T_{\text{avg rotation}} = 1/2 \times 1/\text{RPMs} \times 60 \text{ sec}/1 \text{ min}$
 - Typical $T_{\text{avg rotation}} = 7,200 \text{ RPMs}$

- **Transfer time ($T_{\text{avg transfer}}$)**

- Time to read the bits in the target sector.
 - $T_{\text{avg transfer}} = 1/\text{RPM} \times 1/(\text{avg \# sectors/track}) \times 60 \text{ secs}/1 \text{ min.}$

Disk Access Time Example

■ Given:

- Rotational rate = 7,200 RPM
- Average seek time = 9 ms.
- Avg # sectors/track = 400.

■ Derived:

- $T_{\text{avg rotation}} =$
- $T_{\text{avg transfer}} =$
- $T_{\text{access}} =$

■ Average time to access some target sector approximated by:

- $T_{\text{access}} = T_{\text{avg seek}} + T_{\text{avg rotation}} + T_{\text{avg transfer}}$

■ Seek time ($T_{\text{avg seek}}$)

- Time to position heads over cylinder containing target sector.
- Typical $T_{\text{avg seek}}$ is 3—9 ms

■ Rotational latency ($T_{\text{avg rotation}}$)

- Time waiting for first bit of target sector to pass under r/w head.
- $T_{\text{avg rotation}} = 1/2 \times 1/\text{RPMs} \times 60 \text{ sec}/1 \text{ min}$
- Typical $T_{\text{avg rotation}} = 7,200 \text{ RPMs}$

■ Transfer time ($T_{\text{avg transfer}}$)

- Time to read the bits in the target sector.
- $T_{\text{avg transfer}} = 1/\text{RPM} \times 1/(\text{avg \# sectors/track}) \times 60 \text{ secs}/1 \text{ min.}$

Disk Access Time Example

■ Given:

- Rotational rate = 7,200 RPM
- Average seek time = **9 ms**.
- Avg # sectors/track = 400.

■ Derived:

- $T_{\text{avg rotation}} = 1/2 \times (60 \text{ secs}/7200 \text{ RPM}) \times 1000 \text{ ms/sec} = \mathbf{4 \text{ ms}}$.
- $T_{\text{avg transfer}} = 60/7200 \text{ RPM} \times 1/400 \text{ secs/track} \times 1000 \text{ ms/sec} = \mathbf{0.02 \text{ ms}}$
- $T_{\text{access}} = \mathbf{9 \text{ ms} + 4 \text{ ms} + 0.02 \text{ ms}}$

■ Important points:

- Access time dominated by seek time and rotational latency.
- First bit in a sector is the most expensive, the rest are free.
- ***SRAM access time is about 4 ns/doubleword, DRAM about 60 ns***
 - ***Disk is about 40,000 times slower than SRAM,***
 - ***2,500 times slower than DRAM.***

Logical Disk Blocks

- **Modern disks present a simpler abstract view of the complex sector geometry:**
 - The set of available sectors is modeled as a sequence of b-sized **logical blocks** (0, 1, 2, ...)
- **Mapping between logical blocks and actual (physical) sectors**
 - Maintained by hardware/firmware device called disk controller.
 - Converts requests for logical blocks into (surface, track, sector) triples.
- **Allows controller to set aside spare cylinders for each zone.**
 - Accounts for the difference in “formatted capacity” and “maximum capacity”.

I/O Bus

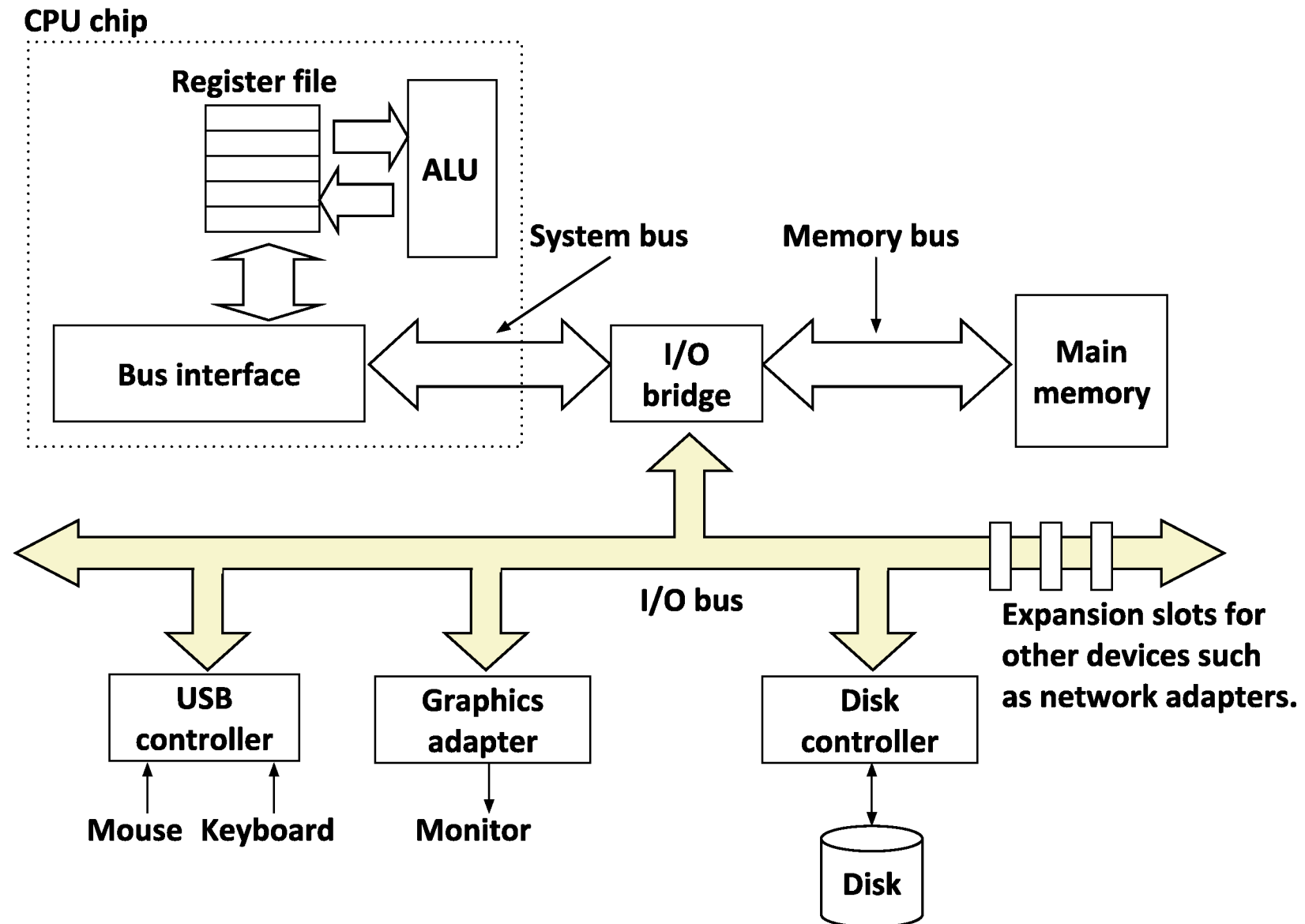

Reading a Disk Sector (1)

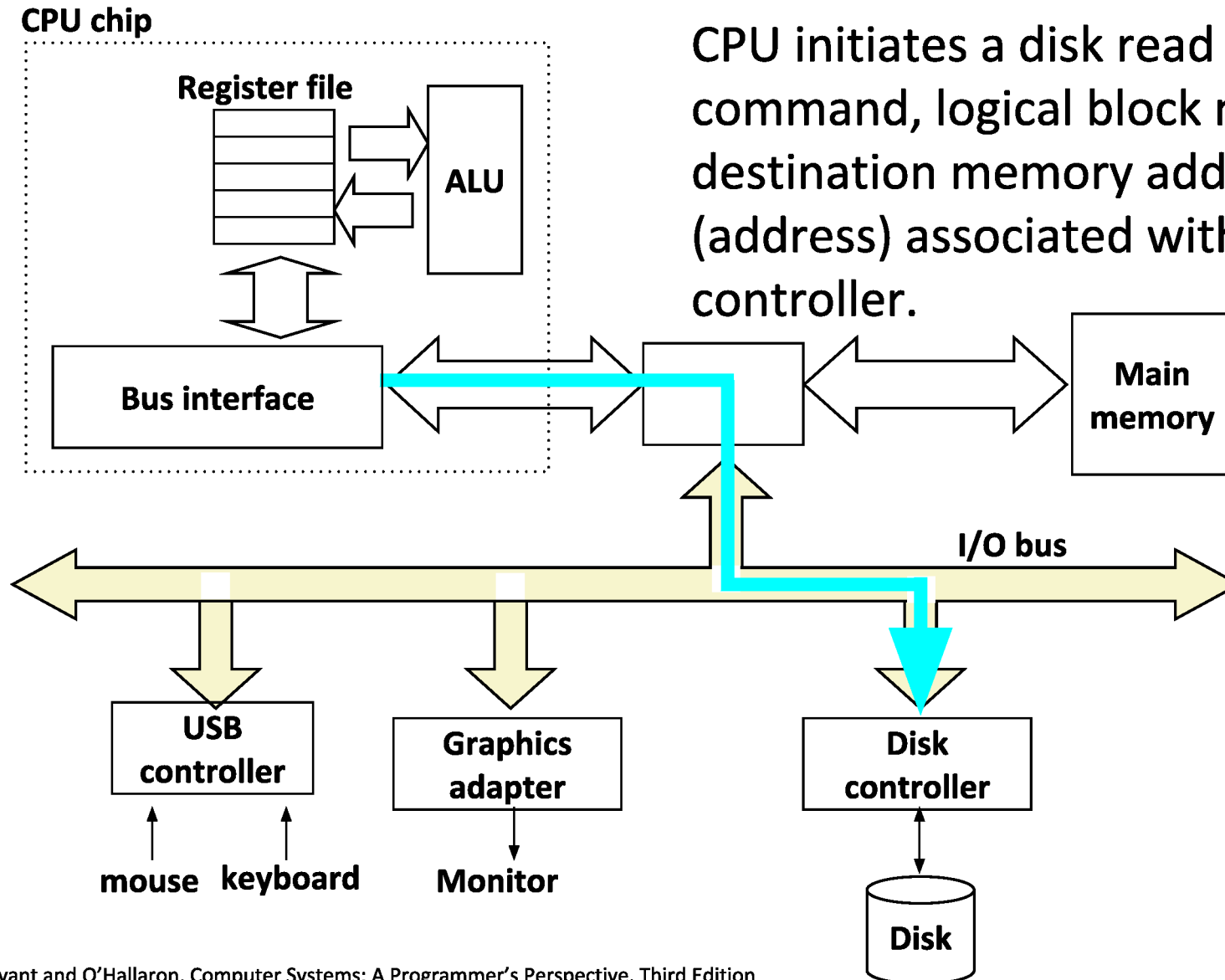

CPU initiates a disk read by writing a command, logical block number, and destination memory address to a **port** (address) associated with disk controller.

Reading a Disk Sector (2)

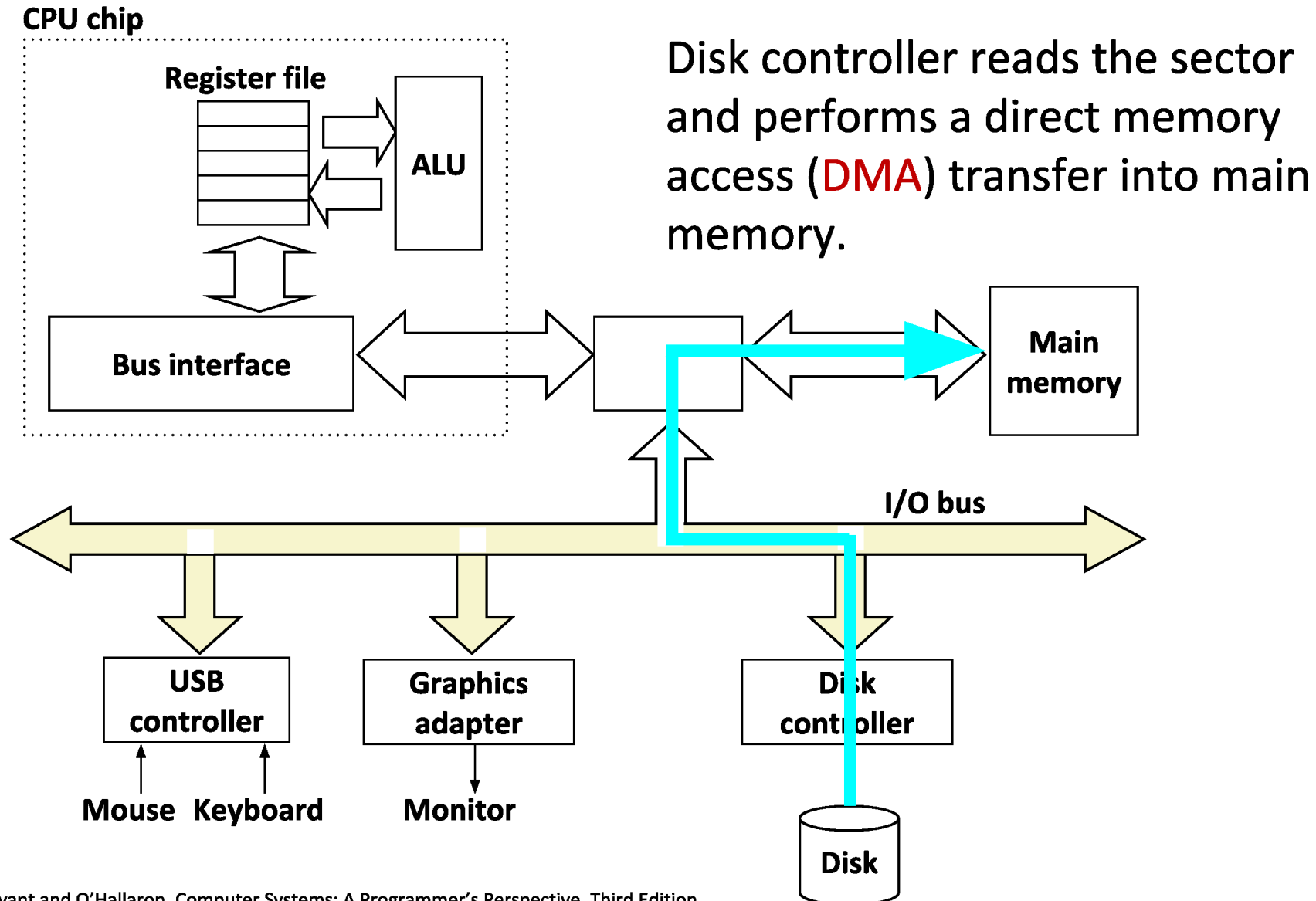

Reading a Disk Sector (3)

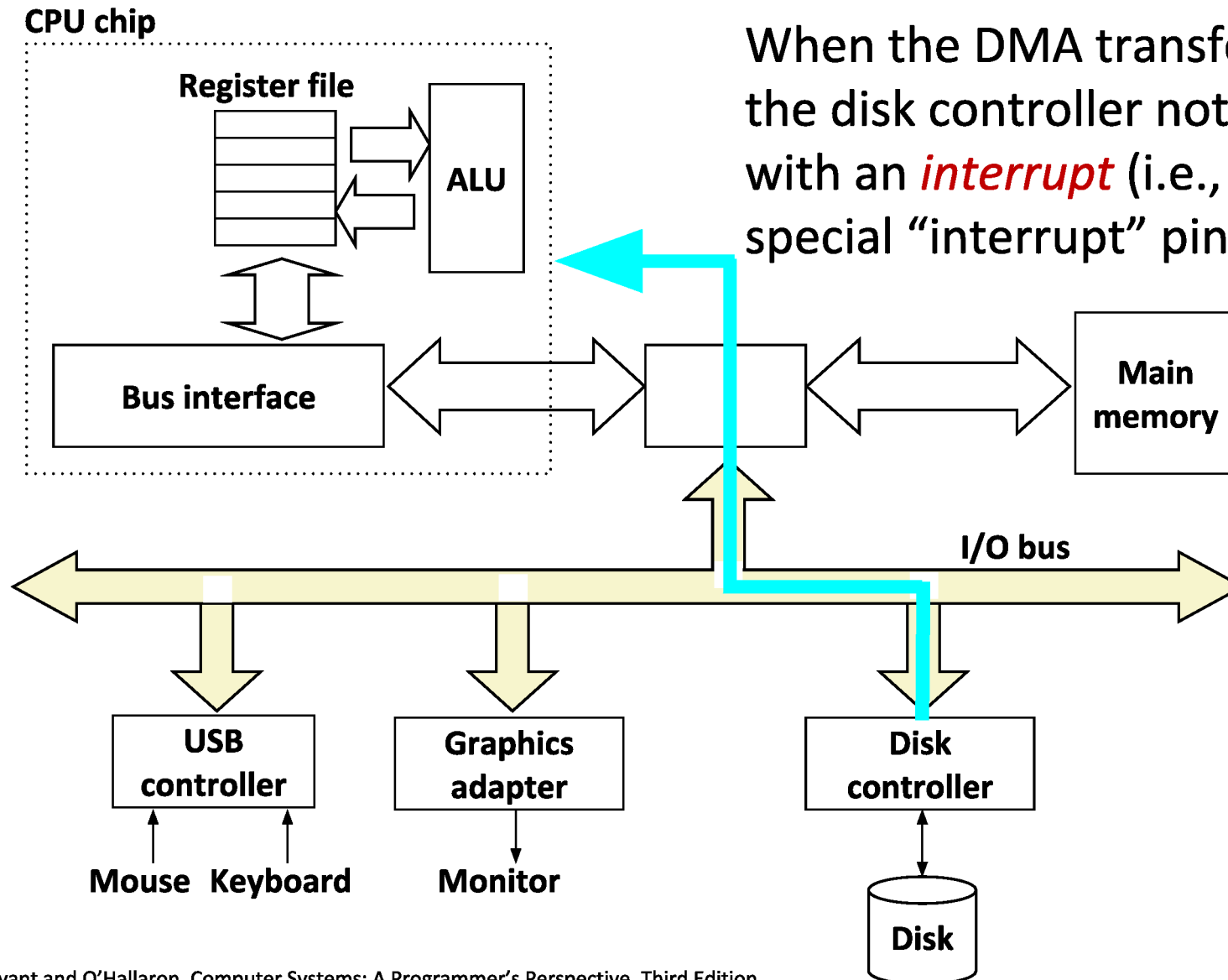

Solid State Disks (SSDs)

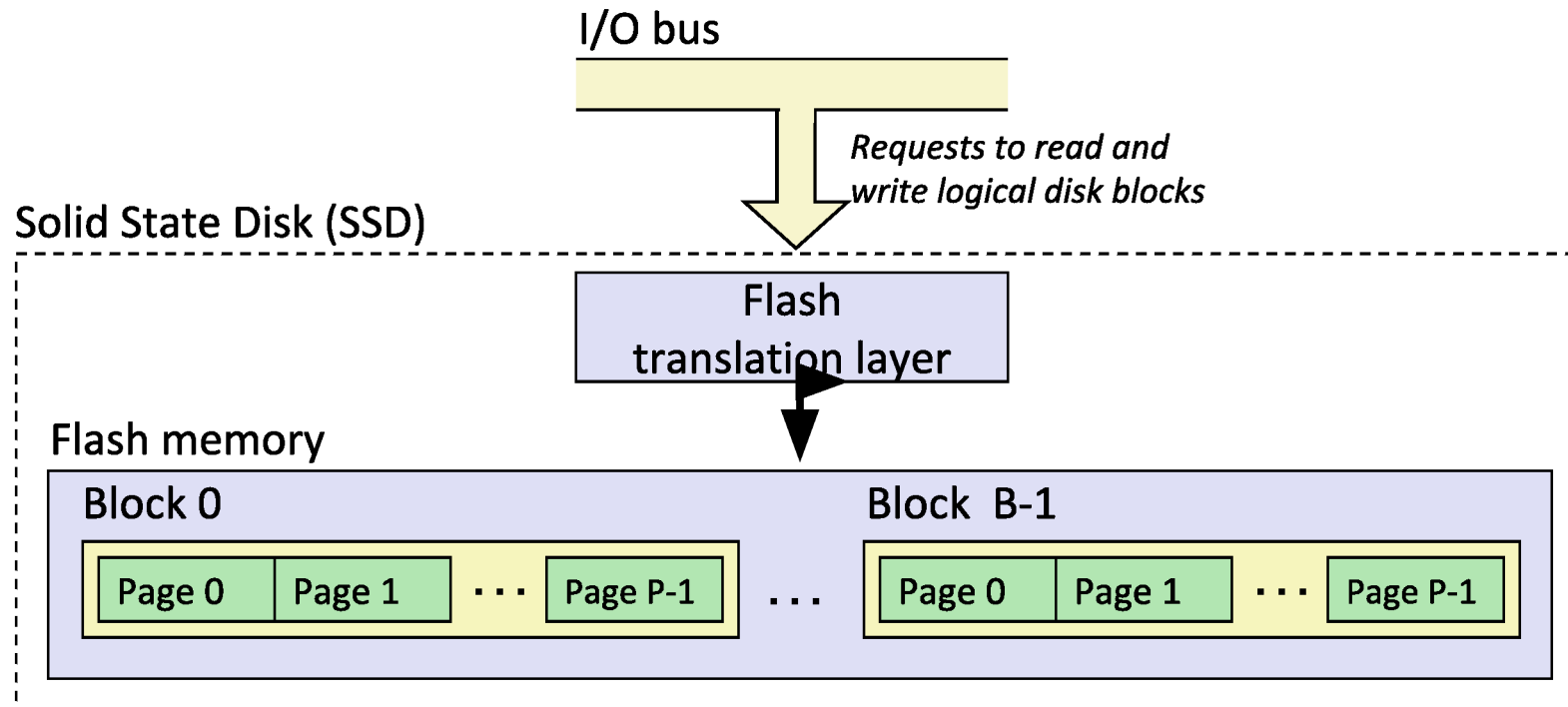

- **Pages: 512KB to 4KB, Blocks: 32 to 128 pages**
- **Data read/written in units of pages.**
- **Page can be written only after its block has been erased**
- **A block wears out after about 100,000 repeated writes.**

SSD Performance Characteristics

Sequential read tput	550 MB/s	Sequential write tput	470 MB/s
Random read tput	365 MB/s	Random write tput	303 MB/s
Avg seq read time	50 us	Avg seq write time	60 us

- **Sequential access faster than random access**
 - Common theme in the memory hierarchy
- **Random writes are somewhat slower**
 - Erasing a block takes a long time (~1 ms)
 - Modifying a block page requires all other pages to be copied to new block
 - In earlier SSDs, the read/write gap was much larger.

Source: Intel SSD 730 product specification.

SSD Tradeoffs vs Rotating Disks

■ Advantages

- No moving parts → faster, less power, more rugged

■ Disadvantages

- Have the potential to wear out
 - Mitigated by “wear leveling logic” in flash translation layer
 - E.g. Intel SSD 730 guarantees 128 petabyte (128×10^{15} bytes) of writes before they wear out
- In 2015, about 30 times more expensive per byte

■ Applications

- MP3 players, smart phones, laptops
- Beginning to appear in desktops and servers

The CPU-Memory Gap

The gap *widens* between DRAM, disk, and CPU speeds.

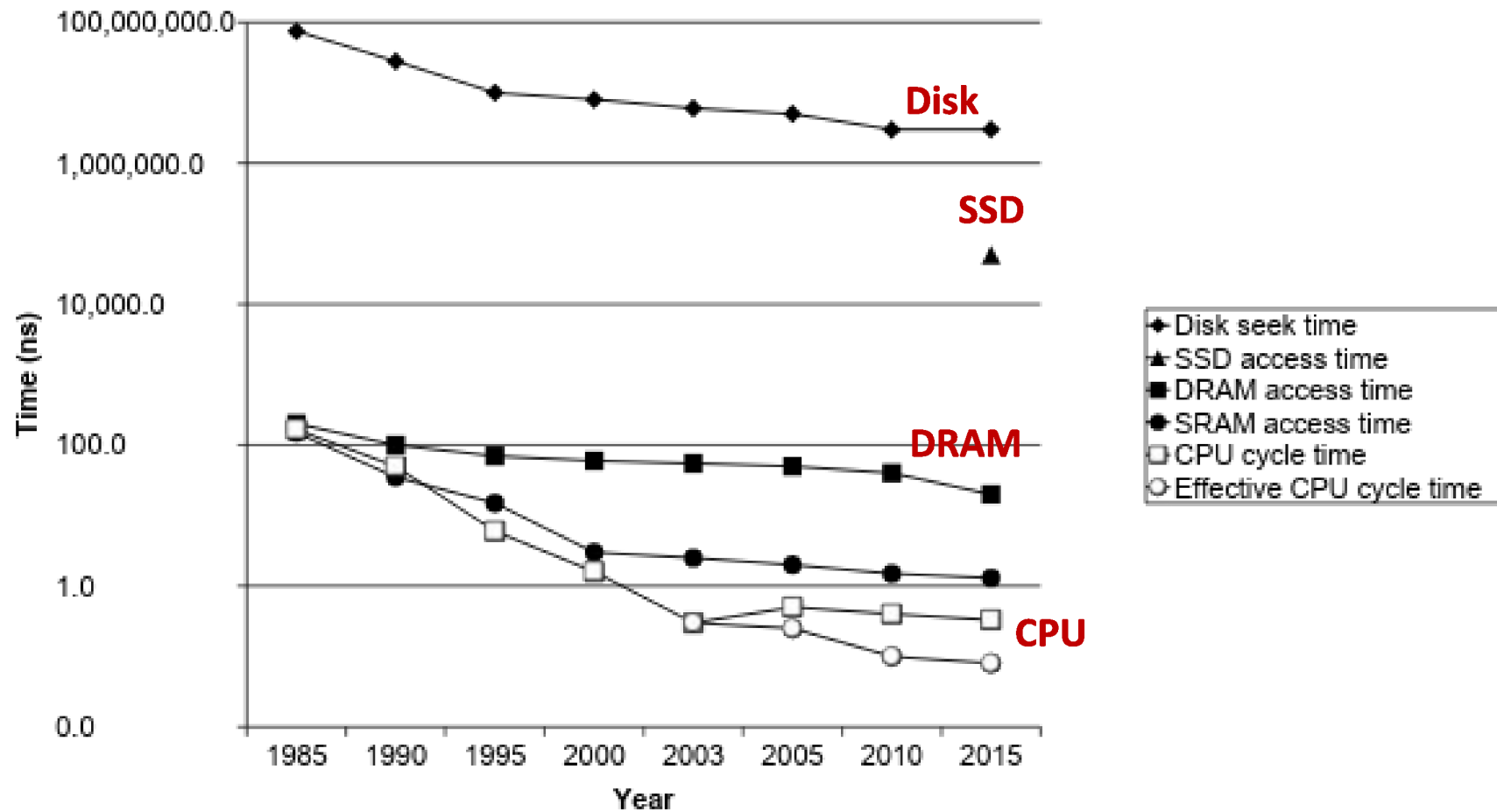

Locality to the Rescue!

The key to bridging this CPU-Memory gap is a fundamental property of computer programs known as **locality**

Today

- Storage technologies and trends
- **Locality of reference**
- Caching in the memory hierarchy

Locality

- **Principle of Locality:** Programs tend to use data and instructions with addresses near or equal to those they have used recently

- **Temporal locality:**
 - Recently referenced items are likely to be referenced again in the near future

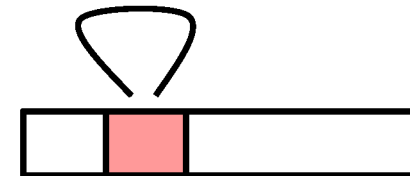

- **Spatial locality:**
 - Items with nearby addresses tend to be referenced close together in time

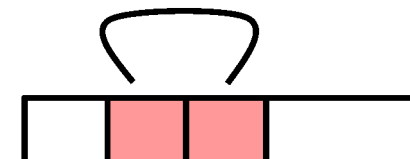

Locality Example

```
sum = 0;
for (i = 0; i < n; i++)
    sum += a[i];
return sum;
```

■ Data references

- Reference array elements in succession (stride-1 reference pattern).
- Reference variable `sum` each iteration.

■ Instruction references

- Reference instructions in sequence.
- Cycle through loop repeatedly.

Spatial locality

**Temporal
locality**

Spatial locality

**Temporal
locality**

Qualitative Estimates of Locality

- **Claim:** Being able to look at code and get a qualitative sense of its locality is a key skill for a professional programmer.
- **Question:** Does this function have good locality with respect to array `a`?

```
int sum_array_rows(int a[M][N])
{
    int i, j, sum = 0;

    for (i = 0; i < M; i++)
        for (j = 0; j < N; j++)
            sum += a[i][j];
    return sum;
}
```

Locality Example

- **Question:** Does this function have good locality with respect to array *a*?

```
int sum_array_cols(int a[M][N])
{
    int i, j, sum = 0;

    for (j = 0; j < N; j++)
        for (i = 0; i < M; i++)
            sum += a[i][j];
    return sum;
}
```

Locality Example

- **Question:** Can you permute the loops so that the function scans the 3-d array `a` with a stride-1 reference pattern (and thus has good spatial locality)?

```
int sum_array_3d(int a[M][N][N])
{
    int i, j, k, sum = 0;

    for (i = 0; i < N; i++)
        for (j = 0; j < N; j++)
            for (k = 0; k < M; k++)
                sum += a[k][i][j];
    return sum;
}
```

Memory Hierarchies

- **Some fundamental and enduring properties of hardware and software:**
 - Fast storage technologies cost more per byte, have less capacity, and require more power (heat!).
 - The gap between CPU and main memory speed is widening.
 - Well-written programs tend to exhibit good locality.
- **These fundamental properties complement each other beautifully.**
- **They suggest an approach for organizing memory and storage systems known as a **memory hierarchy**.**

Today

- Storage technologies and trends
- Locality of reference
- **Caching in the memory hierarchy**

Example Memory Hierarchy

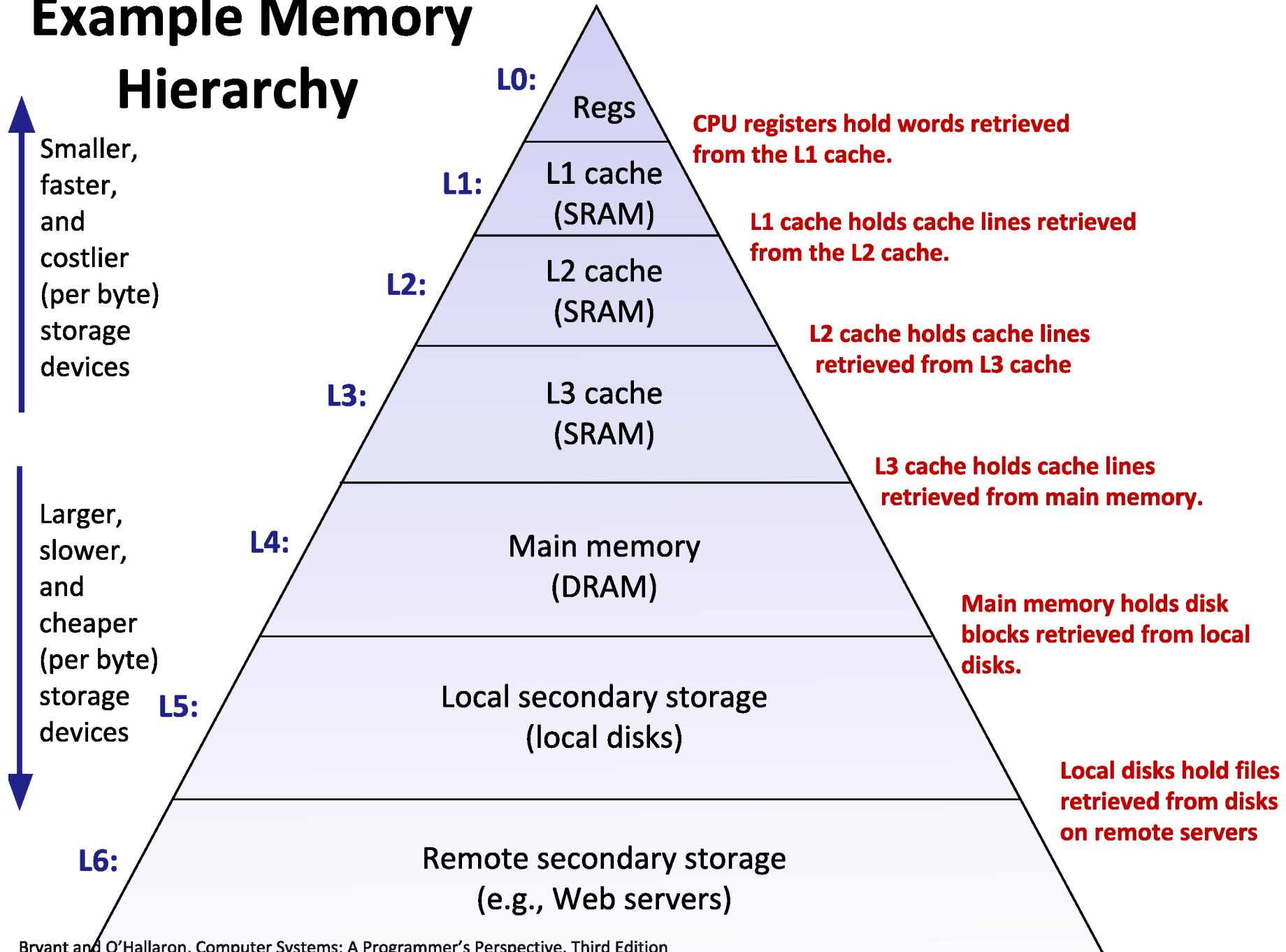

Caches

- **Cache:** A smaller, faster storage device that acts as a staging area for a subset of the data in a larger, slower device.
- **Fundamental idea of a memory hierarchy:**
 - For each k , the faster, smaller device at level k serves as a cache for the larger, slower device at level $k+1$.
- **Why do memory hierarchies work?**
 - Because of locality, programs tend to access the data at level k more often than they access the data at level $k+1$.
 - Thus, the storage at level $k+1$ can be slower, and thus larger and cheaper per bit.
- **Big Idea:** The memory hierarchy creates a large pool of storage that costs as much as the cheap storage near the bottom, but that serves data to programs at the rate of the fast storage near the top.

General Cache Concepts

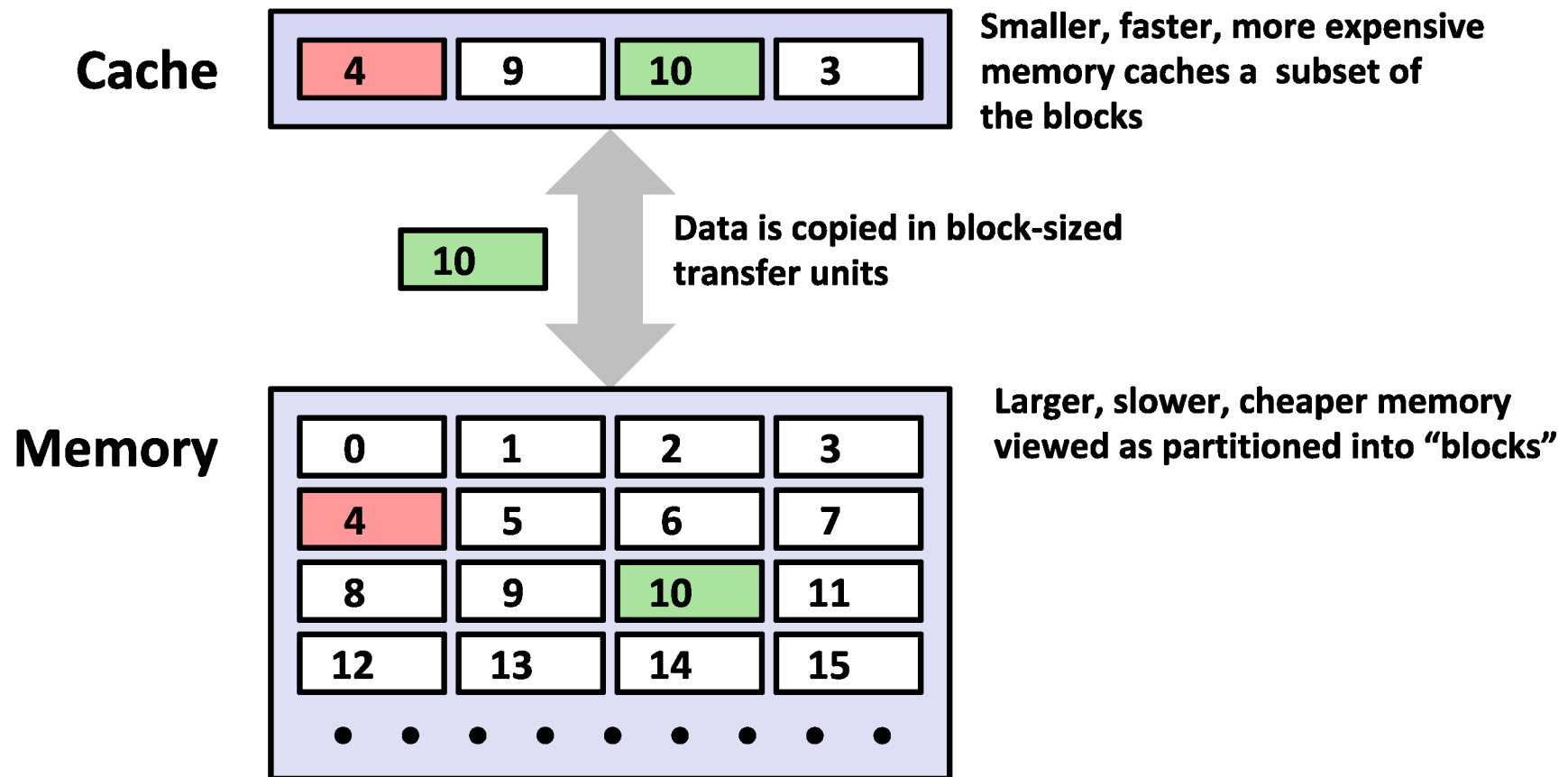

General Cache Concepts: Hit

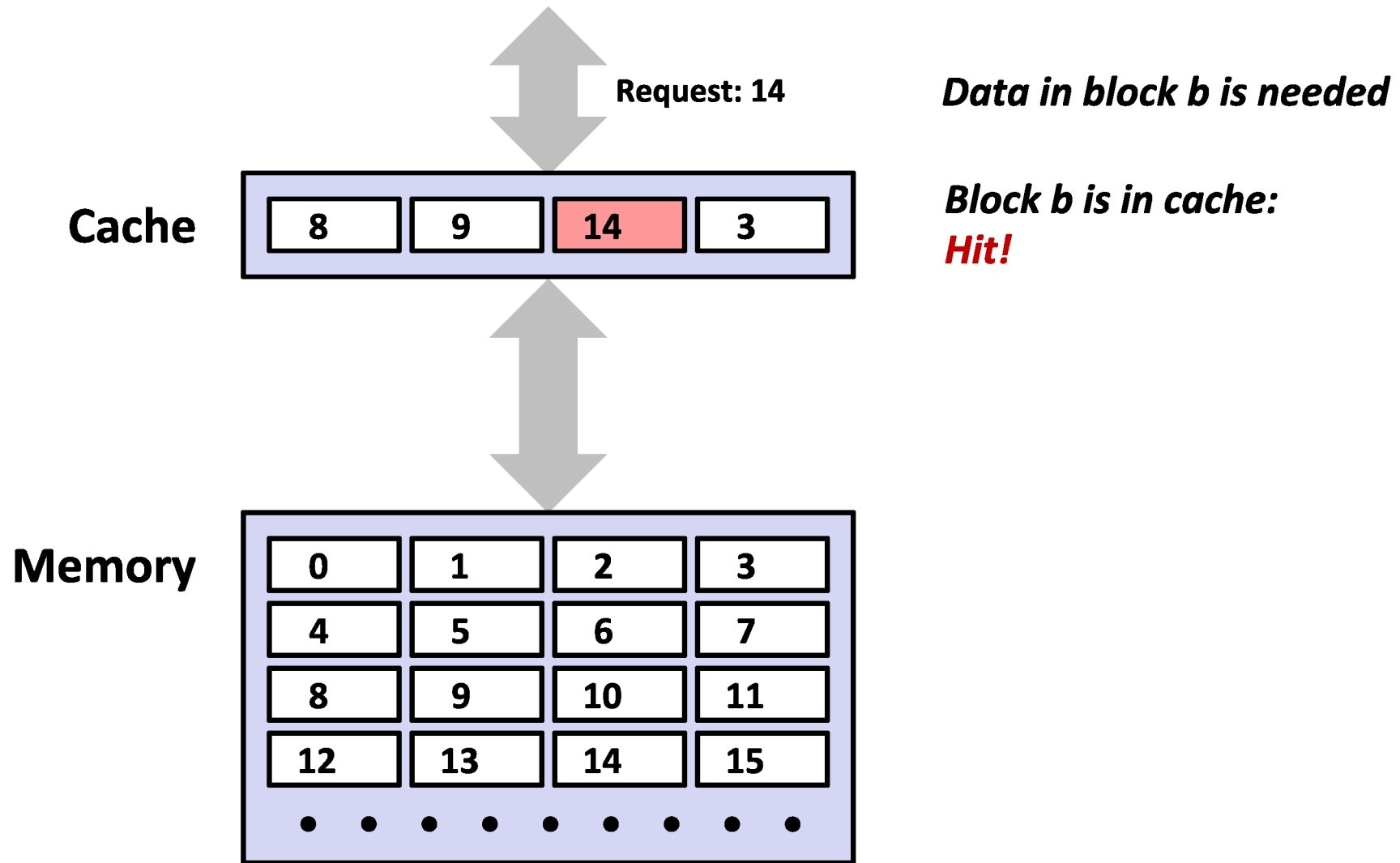

General Cache Concepts: Miss

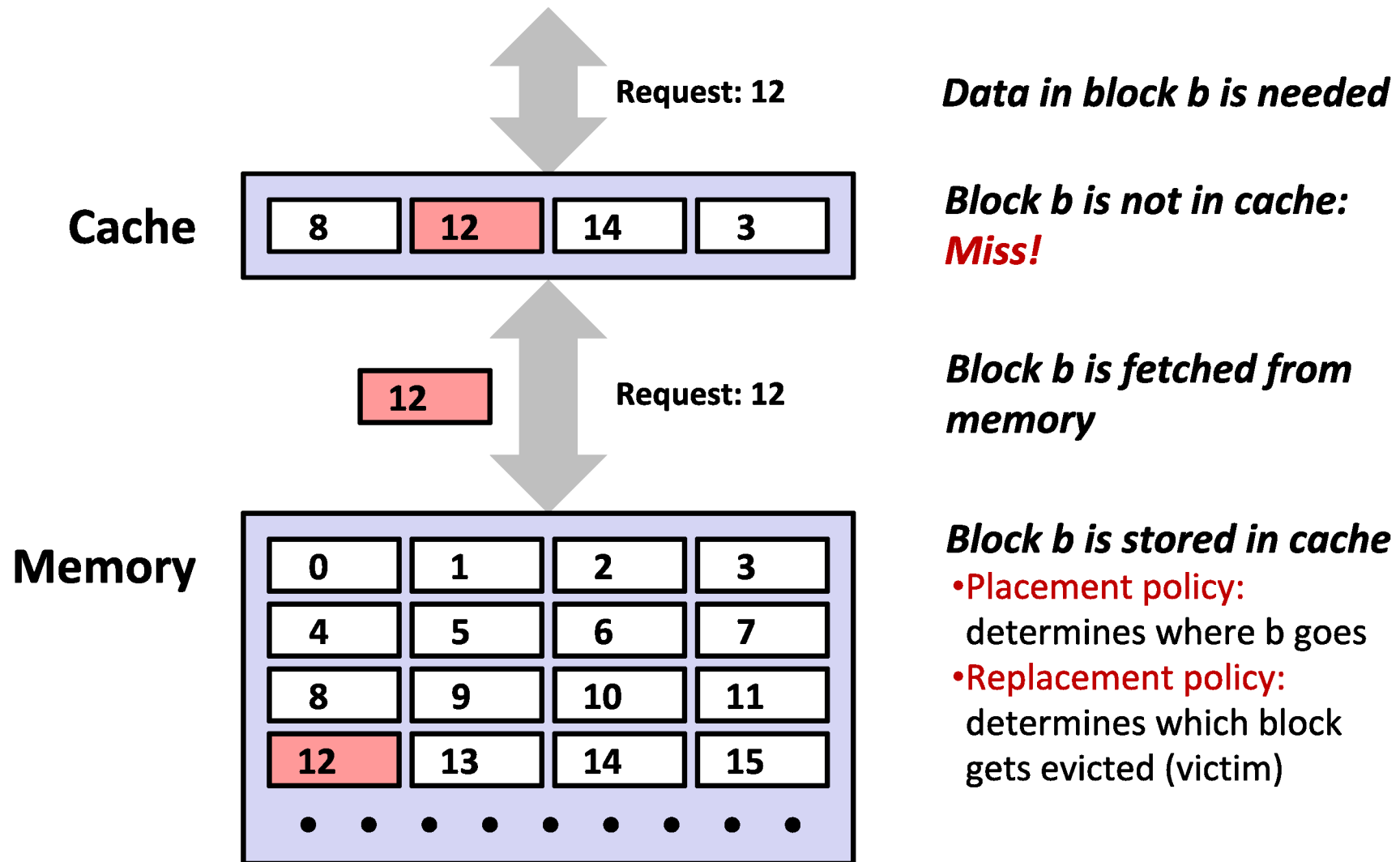

General Caching Concepts:

Types of Cache Misses

■ Cold (compulsory) miss

- Cold misses occur because the cache is empty.

■ Conflict miss

- Most caches limit blocks at level $k+1$ to a small subset (sometimes a singleton) of the block positions at level k .
 - E.g. Block i at level $k+1$ must be placed in block $(i \bmod 4)$ at level k .
- Conflict misses occur when the level k cache is large enough, but multiple data objects all map to the same level k block.
 - E.g. Referencing blocks 0, 8, 0, 8, 0, 8, ... would miss every time.

■ Capacity miss

- Occurs when the set of active cache blocks (**working set**) is larger than the cache.

Examples of Caching in the Mem. Hierarchy

Cache Type	What is Cached?	Where is it Cached?	Latency (cycles)	Managed By
Registers	4-8 bytes words	CPU core	0	Compiler
TLB	Address translations	On-Chip TLB	0	Hardware MMU
L1 cache	64-byte blocks	On-Chip L1	4	Hardware
L2 cache	64-byte blocks	On-Chip L2	10	Hardware
Virtual Memory	4-KB pages	Main memory	100	Hardware + OS
Buffer cache	Parts of files	Main memory	100	OS
Disk cache	Disk sectors	Disk controller	100,000	Disk firmware
Network buffer cache	Parts of files	Local disk	10,000,000	NFS client
Browser cache	Web pages	Local disk	10,000,000	Web browser
Web cache	Web pages	Remote server disks	1,000,000,000	Web proxy server

Summary

- **The speed gap between CPU, memory and mass storage continues to widen.**
- **Well-written programs exhibit a property called *locality*.**
- **Memory hierarchies based on *caching* close the gap by exploiting locality.**

Supplemental slides

Conventional DRAM Organization

- **d x w DRAM:**
 - dw total bits organized as d **supercells** of size w bits

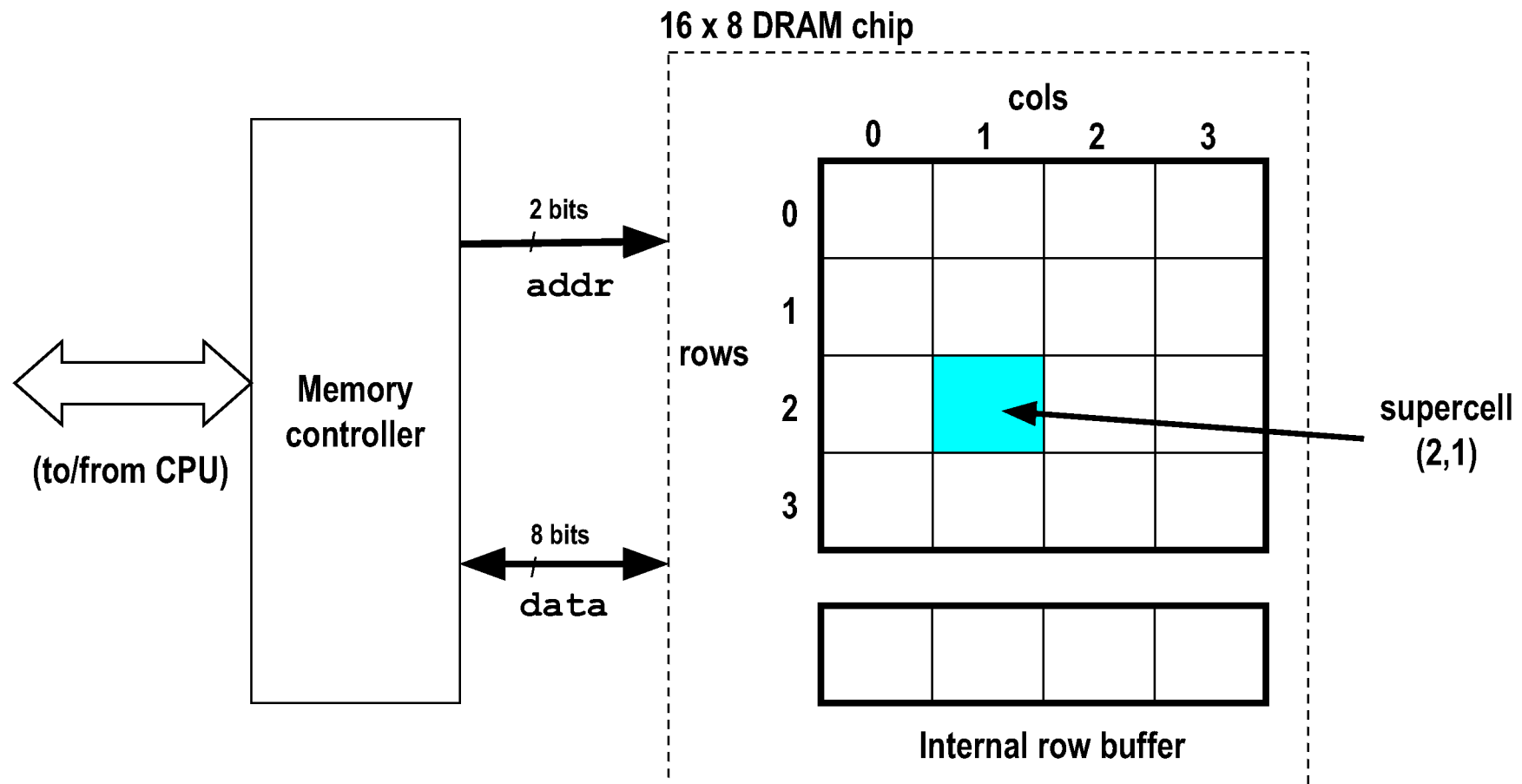

Reading DRAM Supercell (2,1)

Step 1(a): Row access strobe (**RAS**) selects row 2.

Step 1(b): Row 2 copied from DRAM array to row buffer.

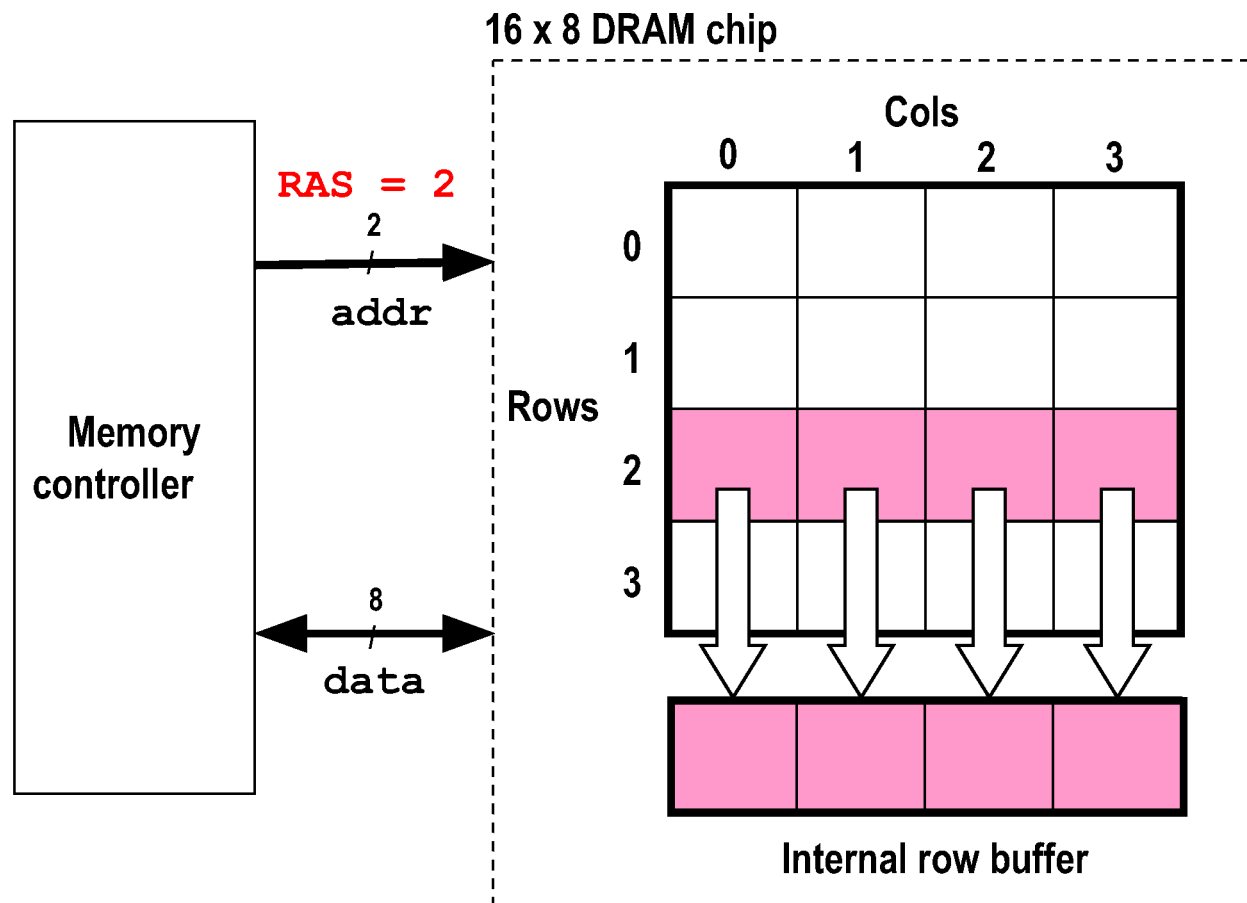

Reading DRAM Supercell (2,1)

Step 2(a): Column access strobe (**CAS**) selects column 1.

Step 2(b): Supercell (2,1) copied from buffer to data lines, and eventually back to the CPU.

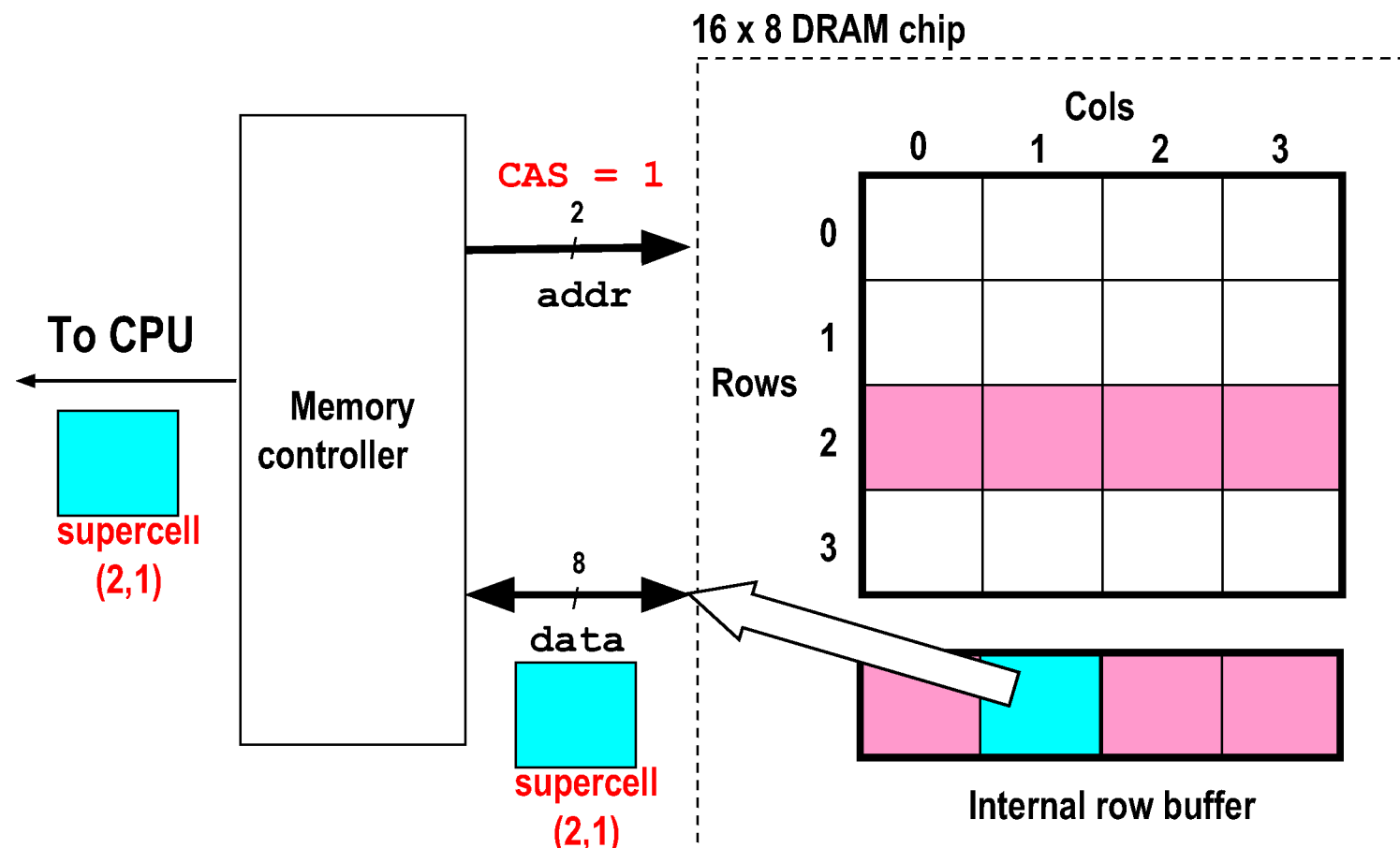

Memory Modules

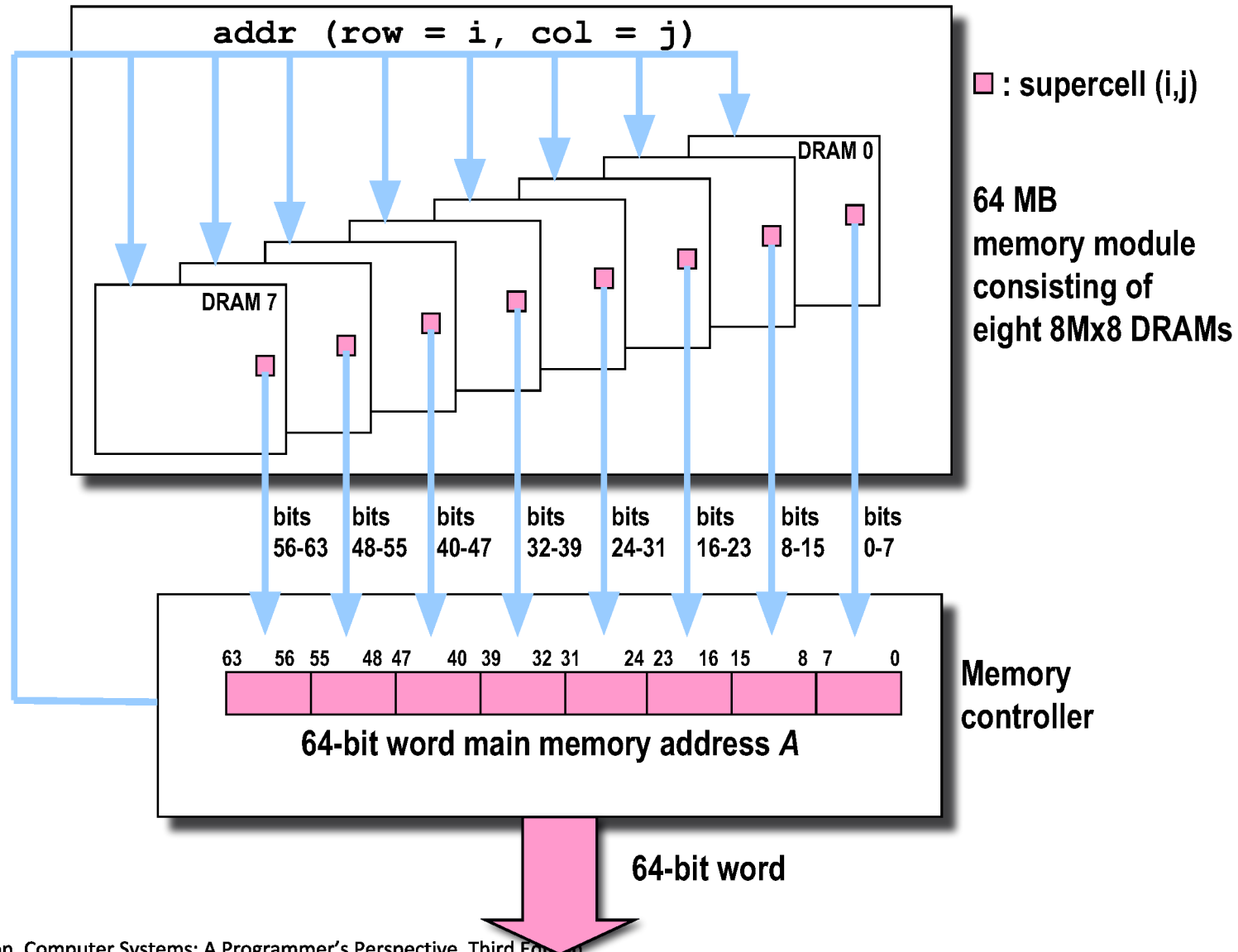

Storage Trends

SRAM

Metric	1985	1990	1995	2000	2005	2010	2015
2015:1985							
\$/MB	2,900	320	256	100	75	60	320 116
access (ns)	150	35	15	3	2	1.5	200 115

DRAM

Metric	1985	1990	1995	2000	2005	2010	2015
2015:1985							
\$/MB	880	100	30	1	0.1	0.06	0.02 44,000
access (ns)	200	100	70	60	50	40	20 10
typical size (MB)	0.256	4	16	64	2,000	8,000	16,000 62,500

Disk

Metric	1985	1990	1995	2000	2005	2010	2015
2015:1985							
\$/GB	100,000	8,000	300	10	5	0.3	0.03 3,333,333
access (ms)	75	28	10	8	5	3	3 25

CPU Clock Rates

Inflection point in computer history
when designers hit the "Power Wall"



	1985	1990	1995	2003	2005	2010	2015	2015:1985
CPU	80286	80386	Pentium	P-4	Core 2	Core i7(n)	Core i7(h)	
Clock rate (MHz)	6	20	150	3,300	2,000	2,500	3,000	500
Cycle time (ns)	166	50	6	0.30	0.50	0.4	0.33	500
Cores	1	1	1	1	2	4	4	4
Effective cycle time (ns)	166	50	6	0.30	0.25	0.10	0.08	2,075

(n) Nehalem processor
(h) Haswell processor